



**EMERGENCY WARNING
and INTERCOMMUNICATION
SYSTEM (EWIS)**

Type 4100

INSTALLATION MANUAL

VOLUME 2 of 3

GLOSSARY OF STANDARD TERMS

The following abbreviations are used throughout this manual:

ACF	Ancillary Control Facility
AZF	Alarm Zone Facility
CPU	Central Processing Unit
E ² PROM	Electrically Erasable Programmable Read Only Memory
EPROM	Erasable Programmable Read Only Memory
FIP	Fire Indicating Panel
IC	Integrated Circuit
LCD	Liquid Crystal Display
LED	Light Emitting Diode
MCU	MicroController Unit
N.O.	Normally Open Relay contact
N.C.	Normally closed Relay contact
PCB	Printed Circuit Board
PSU	Power Supply Unit
RAM	Random Access Memory
ROM	Read Only Memory

MANUFACTURERS DETAILS

APPROVALS: AUSTRALIAN STANDARD AS2220.1 (1989)
SSL CERTIFICATE OF COMPLIANCE NUMBER xxx

The 4100 Evacuation Panel is manufactured by:

Simplex International Time Equipment Pty Ltd
140 Old Pittwater Road
Brookvale N.S.W 2100 Australia
ACN: 008 435 443

Phone: (02)-9466-2333
Fax: (02) 9939 2623

Notice: The contents of this document are subject to change without notice.

AMENDMENTS TO 4100 INSTALLATION MANUAL

ISSUE	SECTION/PAGES AMENDED	DATE AMENDED	COMMENTS	ECN No.
1.0	New Manual	March 1998	Original - File: ewisins	

RELATED DOCUMENTATION

This manual is part of a three volume set relating to the 4100 EWIS Option. The following lists the documentation relating to the 4100 EWIS Option.

Volume 1 4100 EWIS - Operator Manual.
This manual describes the operating procedures for a typical 4100 EWIS Option. 4100 EWIS Operator Manual
Part No/Document No: 4100-M010

Volume 2 4100 EWIS - Installation Manual.
This manual describes the procedures for installing and commissioning typical 4100 EWIS Option. 4100 EWIS Installation Manual
Part No/Document No: 4100-M011

Volume 3 4100 EWIS - Technical Manual.
This manual contains technical descriptions of the various components of typical 4100 EWIS Panel. 4100 EWIS Technical Manual
Part No/Document No: 4100-M012

STANDARDS ASSOCIATION OF AUSTRALIA

This manual makes reference to the following Australian Standards:

AS2220 Emergency warning and intercommunications systems in buildings.
Part 1 and 2 (1989)

AS1670 Automatic Fire Detection and Alarm Systems -
System Design, Installation and Commissioning

TABLE OF CONTENTS

AMENDMENTS TO 4100 INSTALLATION MANUAL	III
<i>RELATED DOCUMENTATION.....</i>	<i>III</i>

STANDARDS ASSOCIATION OF AUSTRALIA	III
1. INTRODUCTION	1
1.1 UNPACKING INVENTORY AND INSPECTION	1
1.2 ANTI STATIC PRECAUTIONS	2
1.3 WORKING ON THE SYSTEM	2
2. INSTALLATION PROCEDURE.....	3
2.1 CABINET INSTALLATION	3
2.1.1 Surface Mount	3
2.1.2 Recess Mount.....	3
2.2 CARD INSTALLATION	3
2.3 INSTALL AND TAG ALL SYSTEM WIRING.....	13
2.4 INSTALL THE PERIPHERAL DEVICES AND E.O.L. RESISTORS.....	13
2.5 BAY DOOR OPTION.....	14
2.6 CHECK AND TERMINATE ALL ZONES	16
2.7 COMPLETE INSTALLATION PROCEDURE.....	18
2.8 INSTALLATION CHECKLIST FOR SIMPLEX TECHNICAL REPRESENTATIVE.....	19
2.8.1 Visual Inspection.....	20
2.8.2 Install Printed Circuit Boards	20
3. FIELD TERMINATIONS	27
3.1 SPEAKER LINE TERMINATIONS.....	27
3.2 EMERGENCY ALARM INITIATING DEVICES TERMINATIONS	31
3.3 FIRE INDICATOR PANEL EWIS TRIP TERMINATIONS.....	34
3.4 VISUAL ALARM DEVICE LINE TERMINATIONS	37
3.5 WIP LINE TERMINATIONS	39
3.6 P.A. MICROPHONE TERMINATIONS	42
3.7 BACKGROUND MUSIC TERMINATIONS	45
3.8 NETWORK WIP PHONE TERMINATION	46
3.8.1 Network WIP Phone Termination – Master Node	48
3.8.2 Network WIP Phone Termination – Slave Node	49
3.9 SECP TERMINATION.....	50
4 PROGRAMMERS REPORT	51
4.1 GENERAL INFORMATION.....	51
4.2 CARD SUMMARY BY LOCATION	52
4.3 SYSTEM POINT SUMMARY	53
4.3.1 Zone Name	53
4.3.2 Address.....	53
4.3.3 Custom Label.....	53
4.3.4 Point Type.....	53
4.4 SYSTEM OPTION SUMMARY	55
4.5 UNIT DETAIL REPORT	56
4.6 ANNUNCIATOR REPORT.....	57
4.7 DIGITAL PSEUDO POINT SUMMARY.....	58
4.8 ANALOG PSEUDO POINT SUMMARY	58
4.10 POINT LIST DETAIL	61
4.11 OPTIONS DETAIL REPORT	62
4.12 NETWORK INTERFACE REPORT	63
4.13 CUSTOM CONTROL EQUATION LISTING	64
5. PLACING SYSTEM INTO OPERATION	65
5.1 POWER UP PROCEDURES	65
6. OUTPUT LEVEL ADJUSTMENTS.....	67
6.1 SPEAKER VOLUME ADJUSTMENT.....	67
6.2 PA VOLUME ADJUSTMENT	68
6.3 SPEECH MICROPHONE LEVEL ADJUSTMENT.....	69

6.4 BACKGROUND MUSIC ADJUSTMENT	70
7 COMMISSIONING THE SYSTEM	71
7.1 COMMISSIONING CHECK LIST.....	71
7.2 BATTERY/BATTERY CHARGER DETAILS.....	73
7.3 SYSTEM TEST PROCEDURES.....	74
7.4 LAMP TEST	74
7.5 REMOUNTING RETAINER	74
8. APPENDIX A – TROUBLE SHOOTING PROCEDURE.....	75
8.1 GENERAL TROUBLESHOOTING INFORMATION	75
8.2 TROUBLESHOOTING CHART.....	75
8.3 GENERAL SYSTEM FAULTS	78
9. APPENDIX B - EWIS 4100 FAULT MESSAGES.....	81
9.1 CARD TROUBLES.....	81
9.2 BATTERY TROUBLES	82
9.3 EARTH GROUNDS.....	82
9.4 ANNUNCIATOR TROUBLES	83
9.5 4100 LCD DISPLAY FAULT MESSAGES TABLE.....	84
10. APPENDIX C LIST OF INSTALLED EQUIPMENT.....	88

TABLE OF FIGURES

Figure 1 System Hardware Envelope Label	2
Figure 2 System Card Box Label.....	4
Figure 3 Installing the System Cards.....	6
Figure 4 Card Address Label and Address Switch	6
Figure 5 Location of Address Switch SW1 on a Typical 4100 Daughter Card.....	7
Figure 6 Installing the Retainer Panel	9
Figure 7 Mounting the door on the Back Box	13
Figure 8 Location of DIP Switches on Typical Device	14
Figure 9 Device Address Label	14
Figure 10 Removing the Option Bay Door.....	15
Figure 11 Custom Terminal Wiring Identifiers	22
Figure 12 Amplifier Card Terminations for Speakers.....	27
Figure 13 Monitor Card Terminations for Manual Call Points.....	31
Figure 14 Monitor Card Terminations for FIP trips	34
Figure 15 Signal Card Terminations for Visual Alarms Devices	37
Figure 16 Signal Card Terminations for WIPs	39
Figure 17 Pre Amplifier Board Terminations for PA.....	42
Figure 18 Pre Amplifier Board Terminations for BGM	45
Figure 19 Master WIP Phone Network.....	47
Figure 20 WIP Network Master Node Phone Terminations.....	48
Figure 21 WIP Network Slave Node Phone Terminations.....	49
Figure 22 Amplifier Card Adjustments for Speaker Adjustments.....	67
Figure 23 Amplifier Card Adjustments for PA Adjustments	68
Figure 24 Speech Adjustment	69
Figure 25 BGM Adjustment	70
Figure 26 Voltage Chart	77

LIST OF TABLES

Table 1 Acceptable Zone and Signal Circuit Meter Readings	17
Table 2 Printed Circuit Board Addresses	23
Table 3 All Expansion Cards	24
Table 4 24 Point Graphic I/O Card Pluggable Resistors	25
Table 5 GENERAL INFORMATION REPORT	51
Table 6 CARD SUMMARY BY LOCATION REPORT	52
Table 7 SYSTEM POINT SUMMARY REPORT.....	54
Table 8 SYSTEM OPTIONS SUMMARY	55
Table 9 UNIT DETAIL REPORT.....	56
Table 10 LOCAL ANNUNCIATOR REPORT.....	57
Table 11 DIGITAL PSEUDO POINT SUMMARY	58
Table 12 ANALOG PSEUDO POINT SUMMARY	59
Table 13 POINT LIST SUMMARY.....	60
Table 14 POINT LIST DETAIL	61
Table 15 OPTIONS DETAIL REPORT.....	62
Table 16 NETWORK INTERFACE REPORT	63
Table 17 CUSTOM CONTROL EQUATION LISTING.....	64

PANEL DETAILS

panel sticker

4100 Panel supplied by	
Installation location	
Contract/Job Number	
As installed EWIS System drawing number	
Panel Installation date	
Panel Commissioned date	
Maintenance Company	
Telephone	
Service Contact	

This page intentionally left blank

1. INTRODUCTION

This manual provides information for the personnel engaged in the installing, commissioning and maintenance of the 4100 EWIS and is to be used in conjunction with the 4100 Operators Manual.

It is assumed that users of this manual are:

- a) Familiar with the operation of the 4100 EWIS Panel.
- b) Trained to install and service microprocessor based EWIS and fire alarm equipment.

NOTES:

- A. Indexes for the **4100 Field Wiring Diagram** are found on the first page of the document.
- B. All wiring must be in accordance with local codes.
- C. A page entitled "GENERAL WIRING PRECAUTIONS" is included in the **4100 Field Wiring Diagram**.

If possible, proceed through the installation process in the sequence that follows.

1.1 UNPACKING INVENTORY AND INSPECTION

Carefully check packing prior to unpacking goods for any external transit damage. Unpack the goods and check the goods both externally and internally for any loose or damaged components or any problems which may effect the appearance, installation or operation of the goods.

Ensure all wiring harnesses are secure, all plugs are correctly fitted into their sockets, each circuit board is secure, and that all fixings and earth studs are tight.

If a plug-in type circuit board or ribbon connector becomes dislodged in transit, replace it in its socket and ensure that it is correctly mated.

If any damage has occurred you are to contact Simplex.

*** * * IMPORTANT * * ***

The contractor **IS NOT** responsible for inventorying or installing daughter cards, or for interconnecting panel components.

- All cartons that contain daughter cards are to be opened, inventoried, and installed by Simplex personnel.

- In addition to the envelope that contained this publication and the material listed in the Packaging Information section of the *Factory Documentation*, supplied material includes an envelope labelled *System Hardware*, as shown in Figure 1.

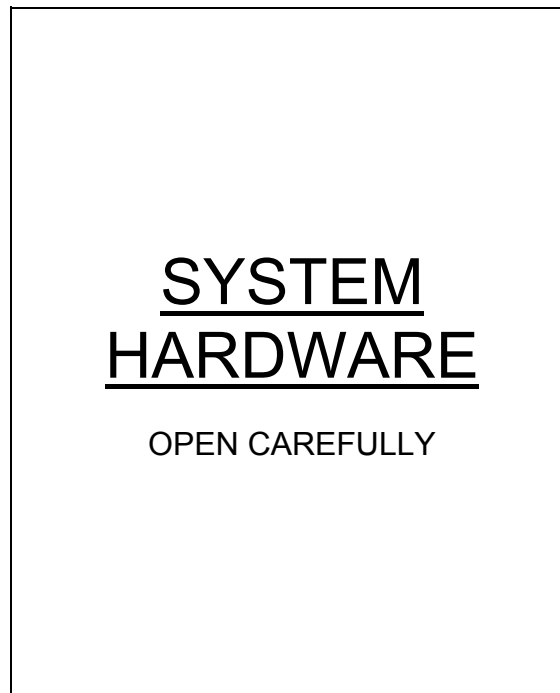

Simplex SIMPLEX TIME RECORDER CO.
GARDNER, MA 01441 U.S.A.

570210-A

Figure 1 System Hardware Envelope Label

1.2 ANTI STATIC PRECAUTIONS

To prevent damage to panel components please ensure prior to touching or handling any of the wiring or printed circuit boards within the EWIS that you are correctly earthed. The recommended method for personnel earthing is to use an anti static wrist strap and a flexible lead. Fit the wrist strap to yourself and attach the flexible lead to the cabinet earth bolt located inside the top of the cabinet.

Printed circuit boards removed from the EWIS should be immediately placed in the anti static bags provided.

1.3 WORKING ON THE SYSTEM

To prevent damage to panel components please ensure prior to unplugging any connector, connecting or disconnecting any wiring, removing or replacing any module or board, that both the mains and batteries have been isolated. Batteries can be isolated by unplugging the battery interconnection harness.

2. INSTALLATION PROCEDURE

2.1 CABINET INSTALLATION

The 4100 EWIS system cabinet should be mounted such that all indicators and controls are not less than 750 mm and not more than 1850 mm from the floor level.

2.1.1 Surface Mount

For surface mount, 4 bolts secure the Back Box cabinet or screws through predrilled 12 mm holes on the rear of the cabinet.

2.1.2 Recess Mount

For a recess mounting of the Back Box cabinet allow a cut out equal to the size of the cabinet plus 10mm all round clearance.

2.2 CARD INSTALLATION

The following instructions provide a systematic method for installing system printed circuit boards (or cards) in a 4100 EWIS system if these are not already installed.

STEP #	ACTION
<input type="checkbox"/> 1.	Open each system card box and remove the system cards from the container.
<input type="checkbox"/> 2.	Install the master control card.
<input type="checkbox"/> 3.	Install the RS-232/2120 Communications Card or the RS-485 Network Interface Card.
<input type="checkbox"/> 4.	Install the daughter cards.
<input type="checkbox"/> 5.	Verify all cabling and wiring harness connections. Refer to Simplex field wiring Diagram (Part No. 841-731).
<input type="checkbox"/> 6.	Verify all system wiring is terminated at specified terminal locations as specified by Simplex Field Wiring Diagram (Part No. 841-731)
<input type="checkbox"/> 7.	Perform a complete system test of all installed devices.
<input type="checkbox"/> 8.	Install and secure the retainer panel on the back box.
<input type="checkbox"/> 9.	Mount the door on the back box.

- 10. Close and lock the panel door.

All system electronics shipments include a small cardboard box (or boxes) containing the system cards. Each box is marked as shown in Figure 2

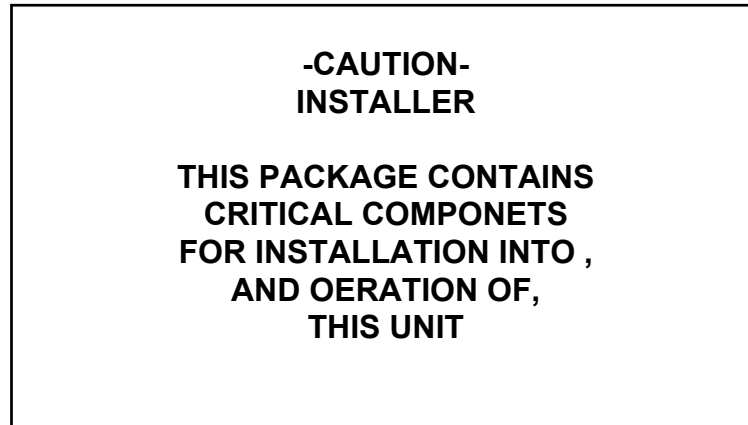

Figure 2 System Card Box Label

Install the system cards in the system electronic bays after installation of the back box and completion of the system field wiring.

To install the system cards, perform the following procedure:-

1. **Make sure that the system ground wire is attached to the green lug screw in the back box.**
2. Inventory the contents of the system card box(es) on a flat surface.
 - Open the system card box(es) and remove the cards.
 - Refer to the factory documentation that accompanies the shipment.
3. Carefully install the Master Controller Card in the left hand slot on the Master Motherboard, located in the CPU bay (See Figure 3.)
4. **4100 Panels:** Carefully install the RS-232/2120 Communication Card (if Supplied) in the right hand slot on the Master Motherboard (See Figure 3).
5. **4120 Network Panels:** Carefully install the RS-485 Network Interface Card in the right hand slot on the Master Motherboard (See Figure 3).

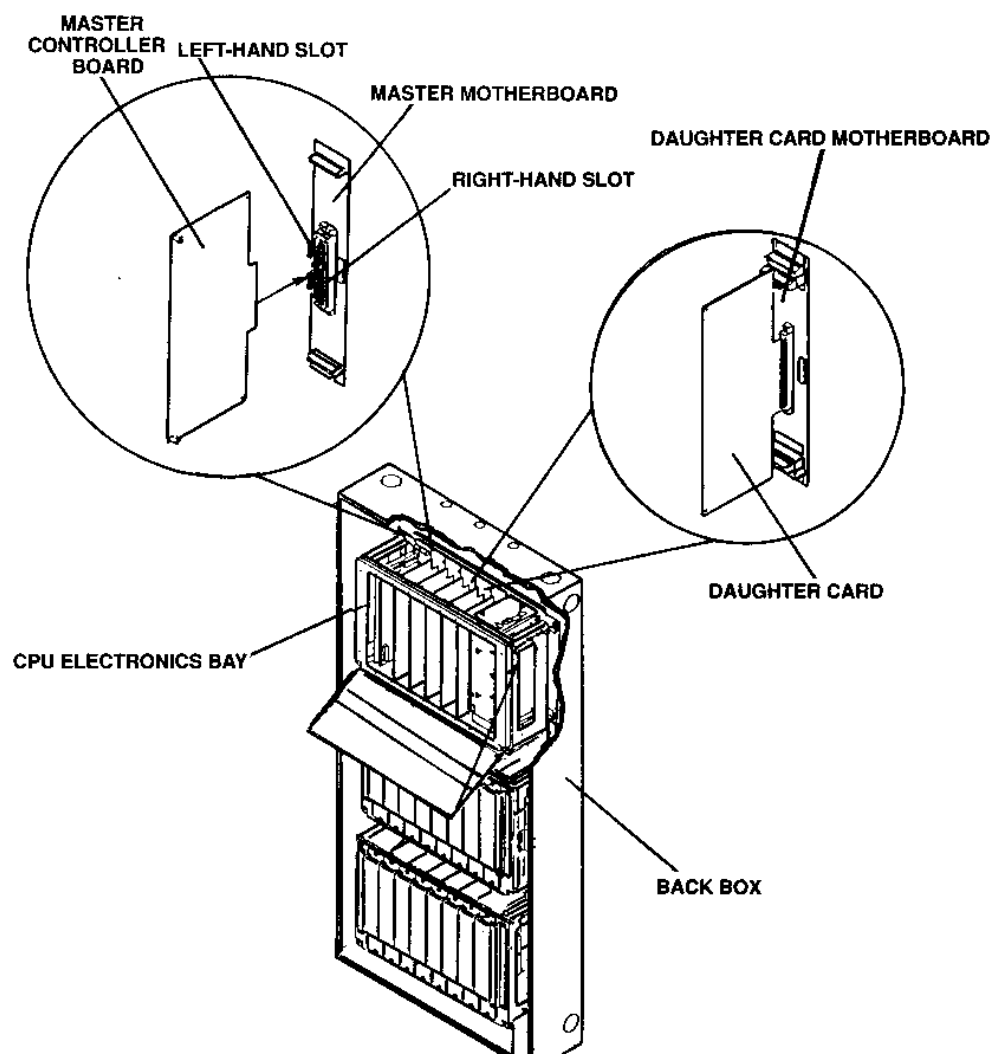
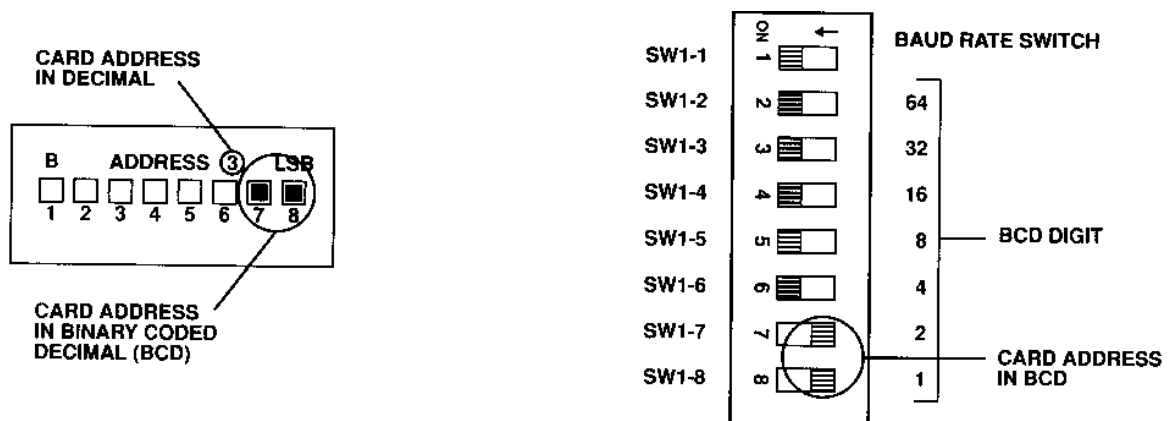

Figure 3 Installing the System Cards

6. Carefully install each daughter Card into its proper slot on its motherboard (See Figure 3.), making certain that the preset configuration of the daughter card address switch, SW1, matches the daughter card address label (located next to the daughter card's motherboard).
 - The relationship between Address Switch SW1 and the card address label is shown in Figure 4.

**Figure 4 Card Address Label and Address Switch**

- The location of Address Switch SW1 on a typical daughter card is shown in Figure 5.

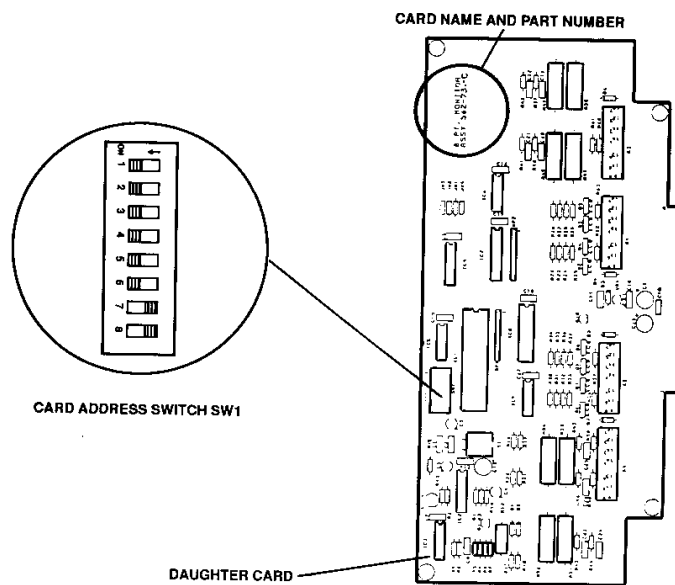

Figure 5 Location of Address Switch SW1 on a Typical 4100 Daughter Card

7. Make certain that all cables and wiring harness are connected in original locations as shipped from the factory.

- Refer to Simplex Field Wiring Diagram (Part No. 841-731).

8. Make certain that all system wiring is terminated at specified terminal locations as specified in the Simplex Field Wiring Diagram (Part No. 841-731).
9. Perform a complete system test of all installed devices.
10. Install the retainer panel on the back box with the retainer clips at the top of the back box (See Figure 6).

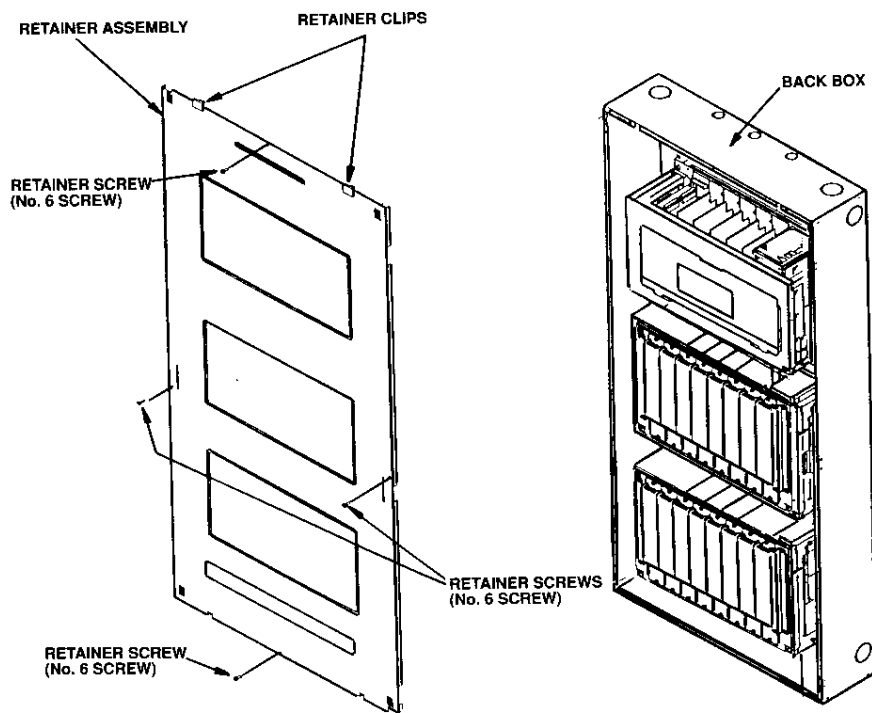

Figure 6 Installing the Retainer Panel

11. Secure the retainer panel using the retainer panel holding screws provided.
12. Remove the panel door from the door box.

13. Mount the door on the back box using the following procedure (See Figure 7).

- a) Lift and place the front door assembly bottom pin into back box hinge hole.
- b) Lift and slide top bolt pin up and across to lower bolt pin.
- c) Move front door assembly into place.
- d) Lift top bolt pin up into locating hole, and slide bolt pin across to drop bolt pin into holding plate.
- e) The door is now mounted onto the back box.

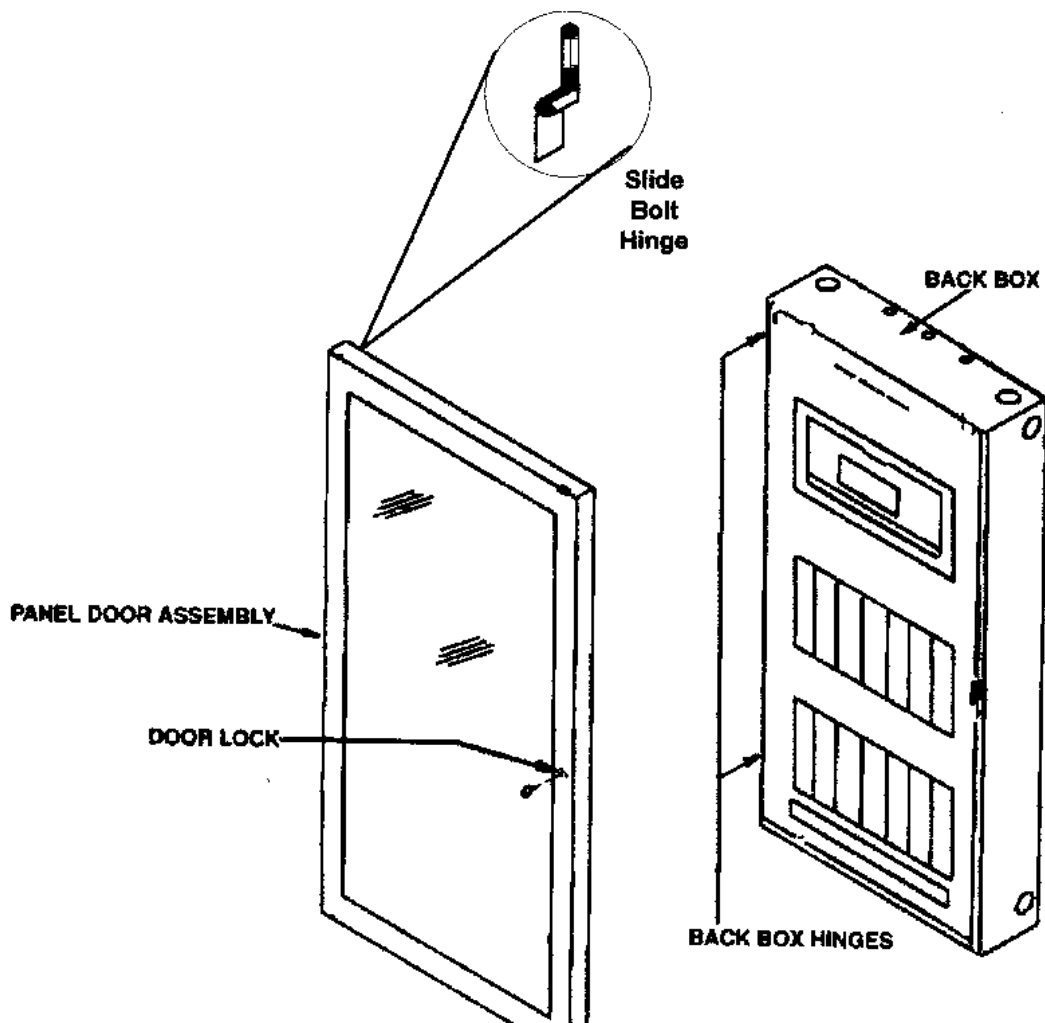

Figure 7 Mounting the door on the Back Box

14. Close and lock the panel door.

2.3 INSTALL AND TAG ALL SYSTEM WIRING.

- See the *SYSTEM POINT SUMMARY* Report (Table 7) and the appropriate page in the *4100 Field Wiring Diagram* (841-731).

2.4 INSTALL THE PERIPHERAL DEVICES AND E.O.L. RESISTORS.

- See Section 3 Field Terminations for details of terminating peripheral devices.
- See the Point Type column in the *SYSTEM POINT SUMMARY* Report for device type.

NOTES:

- A. The **748-200 System Hardware** envelope contains the required resistors.
 - 3.3K (monitor zone) resistors are colour coded orange, orange, red (and have a gold tolerance band); 10K (Notification appliance [signal] circuit) resistors are colour coded brown, black, orange (and also have a gold tolerance band).
 - Resistors other than those described above will be used by the Simplex Technical Representative (T.R.) during installation checkout.
- B. Wire peripherals in accordance with the appropriate **4100 Field Wiring Diagram (841-731)**.
- C. Use a small screwdriver or ball point pen to set device address switches.
- D. After setting the device address, mark the device's address label (Figure 9) to agree with the address switches.

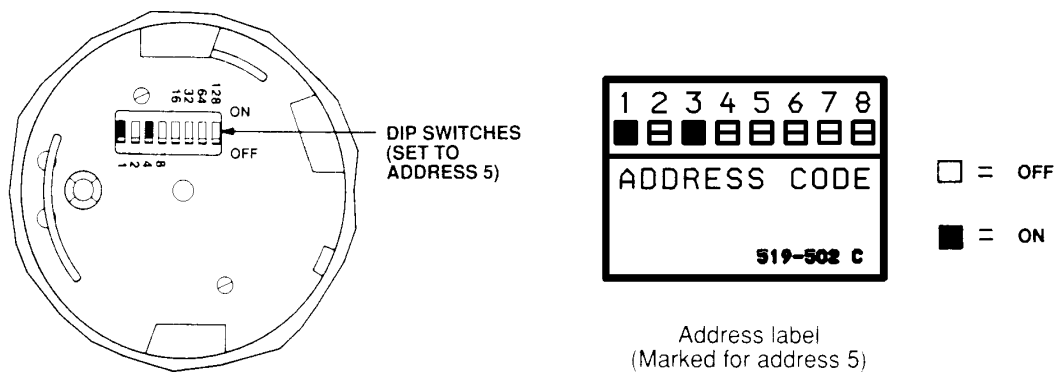

Figure 8 Location of DIP Switches on Typical Device

Figure 9 Device Address Label

2.5 BAY DOOR OPTION.

See Figure 10

- a. (If applicable) Mark the top of the ribbon cable. Then pull the cable straight out of its connector.
- b. Remove the hair-pin cotter pins (item 1) from the upper clevis pins (item 2). Then push the clevis pins inward and lower the door.
- c. Free the lower end of the retainer cable (item 3) by removing the screw and washer (items 4 and 5).
- d. Remove the hair-pin cotter pins (item 6) from the lower clevis pins (item 7). Then push the clevis pins inward and remove the door.
- e. Store the door and its hardware in a safe, clean and dry place until all wires are terminated in the 4100 panel.

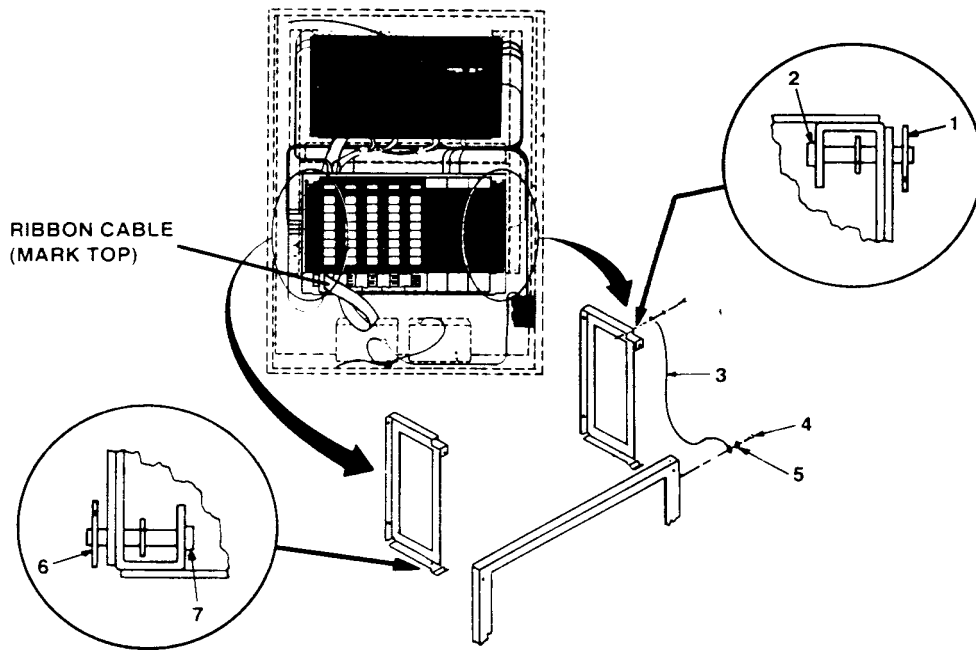

Figure 10 Removing the Option Bay Door

2.6 CHECK AND TERMINATE ALL ZONES

NOTES:

- A. Use the **CARD SUMMARY BY LOCATION** Report (Table 6) to determine the location of the motherboard on which each specific circuit terminates.
- A stick-on “ADDRESS” label on each motherboard identifies that board’s number.
- B. The above report is found within the computer printout portion of the **Factory Documentation**.
- C. Use the terminal identifiers to find specific terminals.
- See Figure 11(Custom Terminal Wiring Identifiers) for typical custom terminal wiring identifiers.
- D. Check each circuit for voltages, shorts or opens as follows:
1. With the meter set on **300VAC**, read the voltage across the circuit.
 - Meter must read 0 volts.
 2. With the meter set on 60VDC, read the voltage across the circuit again (this time in both directions).
 - Meter must read 0 volts.
 3. With the meter set on **OHMS x 10** and its (+) and (–) leads connected to the circuit’s (+) and (–) wires respectively, check resistance.
 - Readings must compare favourably with those shown in Table 1.
 - If reading indicates an open in a circuit that includes a smoke detector, make sure the detector head(s) are properly mounted and seated.
 - Circuits always read “open” (infinity) if detector power is absent and separately-powered devices (four-wire smoke detectors) are involved.
- E. Connect the wires to their terminals.

<i>Circuit Type</i>	<i>Meter Reading</i>
Style B (formerly Class B) Initiating Device (Zone) Circuit	
From zone + to zone – (each zone)	3.3K ohms
From zone + to ground	Infinity
From zone – to ground	Infinity
Style D (formerly Class A) Initiating Device (Zone) Circuit	
From zone + to zone – (each zone)	Infinity
From zone + to ground	Infinity
From zone – to ground	Infinity
From zone + OUT to + IN	Less than 50 ohms
From zone – OUT to – IN	Less than 50 ohms
Style Y (formerly Class B) Notification Appliance Circuit (each signal circuit)	
From + to ground	Infinity
From – to ground	Infinity
Resistance across circuit	
In one direction	10K ohms
In opposite direction	Less than 200 ohms
Style Z (formerly Class A) Notification Appliance Circuit (each signal circuit)	
From + to ground	Infinity
From – to ground	Infinity
From + OUT to + IN	Less than 50 ohms
From – OUT to – IN	Less than 50 ohms
Resistance across circuit	
In one direction	Infinity
In opposite direction	Less than 200 ohms
Shielding	
Shield to ground	Infinity
Shield to –	Infinity
Shield to +	Infinity

Table 1 Acceptable Zone and Signal Circuit Meter Readings

2.7 COMPLETE INSTALLATION PROCEDURE

- A. Check and terminate all remaining circuits (AC Power, AUX, FB etc.).
- B. Dress the panel wiring
 - Use the tie wraps in the system hardware envelope to neatly dress the panel wiring.
- C. Install the option bay door.
- D. Call your local Simplex Branch Office (listed in the Yellow Pages) to install the printed circuit boards and test the system.

**ONLY SIMPLEX REPRESENTATIVES ARE AUTHORISED TO APPLY
AC OR BATTERY POWER TO THE 4100 EWIS SYSTEM.**

2.8 INSTALLATION CHECKLIST FOR SIMPLEX TECHNICAL REPRESENTATIVE

Step	Procedure	Page
<input type="checkbox"/>	1. Use the Packing List in the "Layout" pages to verify delivery/availability of all required system hardware. This includes the printed circuit boards.	1
<input type="checkbox"/>	2. Unlock, then open the panel door. Remove the retainer by removing the top and bottom screws, then squeeze and pull the two black plastic tabs located on the upper part of the retainer. Lift the retainer from the back box.	3
<input type="checkbox"/>	3. Visually inspect the 4100 system. Verify that all wiring is connected to the panel, to include the unified ground.	3
<input type="checkbox"/>	4. Use a volt/ohmmeter to check system wiring. This includes all wiring to the panel, local and remote annunciators, etc. Check the AC power input to the power supply. Repair required circuits prior to powering up the system.	3
<input type="checkbox"/>	5. Check jumpers, switches, capacitors and resistors on all system printed circuit boards. Match the address label on the motherboard to the address label on the daughter board, then install each daughter board.	3
<input type="checkbox"/>	6. Install all wiring harnesses and cables (except battery). This includes auxiliary relay and signal cables.	9
<input type="checkbox"/>	7. Apply power to the system.	60
	• If the system is trouble-free, perform "System Test Procedures".	68
	• If the system displays abnormal conditions, perform troubleshooting procedures.	70

2.8.1 Visual Inspection

A visual inspection of the panel should be performed prior to installation of printed circuit boards, as they obstruct the view of panel terminations when installed. Visually inspect for the following:

- (a) Neat terminations within the panel.
- (b) System wiring is complete and unused circuits are terminated.
- (c) Terminations are tight.
- (d) Ribbon cables from CPU board are properly installed (both ends).
- (e) Battery cable is connected to the battery test facility P9 of the power master supply or P1 of an expansion power supply.
- (f) Green ground screw is connected to a unified building ground.
- (h) Inspect local and remote annunciators connections.
- (i) Verify that system is clean and free from wire clippings.
- (j) Switches are in the proper position (toggle switches are down).
- (k) Verify that the configuration chip, and revision shown in the main menu, match the Programmer's Report then check the following:
 - (i) File name (8 digits - example: 809005A)
 - (ii) Order number (X digits - example: XXXXXX)
 - (iii) Revision number (3 digits - example: 006)
 - (iv) Date (9 digits - example: 07-JUL-88)

2.8.2 Install Printed Circuit Boards

There are several types of motherboards and printed circuit boards for the 4100 system. Each printed circuit board must be plugged into its proper motherboard for power and communications with the CPU.

Each 4100 printed circuit board has an 8 bit DIP switch (SW1) which is used to set its address and communication baud rate. Verify each address and baud rate prior to installation of each board. The system may contain up to 119 printed circuit cards (each has its own address). The CPU board is always address 0. Each printed circuit board address is a binary address which corresponds with a Custom Terminal Wiring Identifier (white label) on its motherboard, daughterboard and the Programmer's Report.

Match the address label on the motherboard to the address label on the daughterboard, then install each daughterboard. Table 3 (page 26) shows a binary switch setting table which may be used to determine binary address and baud rate.

Dip switch positions 2 through 8 are used for addressing, while dip switch position 1 is used for baud rates selection.

Check switch settings, jumpers and resistors on each printed circuit board prior to installation.

Use the Custom Terminal Wiring Identifiers (same address on motherboard and daughterboard), Layout pages and the Programmer's Report to determine proper address and placement for each printed circuit board. The dip switch on each board has been set to its correct binary address at the factory. This binary address corresponds with a Custom Terminal Wiring Identifier (label) on each motherboard. Match the address on the daughter card with the address label on the motherboard, then insert the card. See Figure 6 (Card Detail Report) for card address example and Figure 18 for an example of a Custom Terminal Wiring Identifier (address 5 for card #5 is shown).

Install the printed circuit boards from left to right, and from top to bottom.

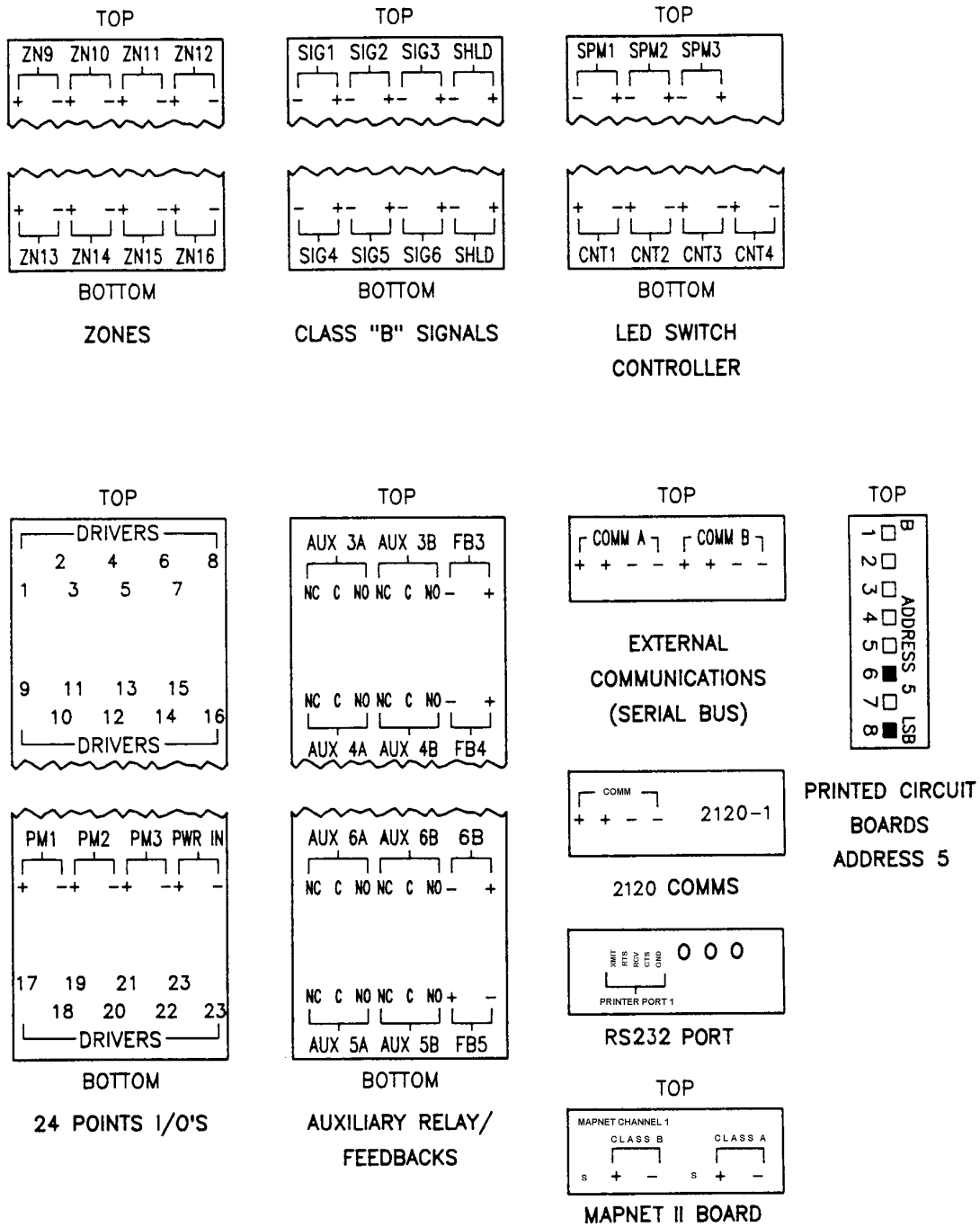
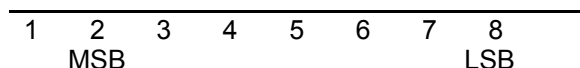
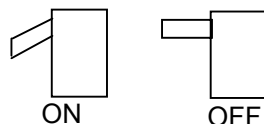

Figure 11 Custom Terminal Wiring Identifiers



Side View of Dip Switch



<u>SW-1</u>	<u>SW1-2</u>	<u>SW1-3</u>	<u>SW1-4</u>	<u>SW1-5</u>	<u>SW1-6</u>	<u>SW1-7</u>	<u>SW1-8</u>	
CPU MODULE IS ALWAYS ADDRESS 0							CPU	= ADDRESS 0
U	ON	ON	ON	ON	ON	ON	OFF	= ADDRESS 1
S	ON	ON	ON	ON	ON	OFF	ON	= ADDRESS 2
E	ON	ON	ON	ON	ON	OFF	OFF	= ADDRESS 3
D	ON	ON	ON	ON	OFF	ON	ON	= ADDRESS 4
F	ON	ON	ON	ON	OFF	ON	OFF	= ADDRESS 5
O	ON	ON	ON	ON	OFF	OFF	ON	= ADDRESS 6
R	ON	ON	ON	OFF	ON	ON	ON	= ADDRESS 7
B	ON	ON	ON	OFF	ON	ON	OFF	= ADDRESS 8
A	ON	ON	ON	OFF	ON	OFF	ON	= ADDRESS 9
U	ON	ON	ON	OFF	ON	OFF	ON	= ADDRESS 10
D	ON	ON	ON	OFF	OFF	ON	ON	= ADDRESS 11
R	ON	ON	ON	OFF	OFF	ON	OFF	= ADDRESS 12
A	ON	ON	ON	OFF	OFF	OFF	ON	= ADDRESS 13
T	ON	ON	OFF	ON	ON	ON	ON	= ADDRESS 14
E	ON	ON	OFF	ON	ON	ON	OFF	= ADDRESS 15
	ON	ON	OFF	ON	ON	OFF	ON	= ADDRESS 16
	ON	ON	OFF	ON	ON	OFF	ON	= ADDRESS 17
	ON	ON	OFF	ON	ON	OFF	ON	= ADDRESS 18
CONTINUES TO A BINARY 119								
ON	OFF	OFF	OFF	ON	OFF	OFF	OFF	= ADDRESS 119

Table 2 Printed Circuit Board Addresses

DIP SWITCH SW1									
ADDRESS AND BAUD RATE SELECT									
SWITCH POSITION	#1	#2	#3	#4	#5	#6	#7	#8	
BRS		MSB				LSB			
BRS = BAUD RATE SELECT 0-9600 baud (INTERNAL/REMOTE)									
ON = 0 OFF = 1									

Table 3 All Expansion Cards

PLUGGABLE RESISTOR SETTINGS			
DRIVE #	RESISTOR #	INPUT	OUTPUT
1	20	2K .5W	20 OHM 1W
2	21	2K .5W	20 OHM 1W
3	22	2K .5W	20 OHM 1W
4	23	2K .5W	20 OHM 1W
5	24	2K .5W	20 OHM 1W
6	25	2K .5W	20 OHM 1W
7	26	2K .5W	20 OHM 1W
8	27	2K .5W	20 OHM 1W
9	28	2K .5W	20 OHM 1W
10	29	2K .5W	20 OHM 1W
11	30	2K .5W	20 OHM 1W
12	31	2K .5W	20 OHM 1W
13	32	2K .5W	20 OHM 1W
14	33	2K .5W	20 OHM 1W
15	34	2K .5W	20 OHM 1W
16	35	2K .5W	20 OHM 1W
17	36	2K .5W	20 OHM 1W
18	37	2K .5W	20 OHM 1W
19	38	2K .5W	20 OHM 1W
20	39	2K .5W	20 OHM 1W
21	40	2K .5W	20 OHM 1W
22	41	2K .5W	20 OHM 1W
23	42	2K .5W	20 OHM 1W
24	43	2K .5W	20 OHM 1W

|
|
 For Input Contact Monitors For Relays LED/Lamps

Table 4 24 Point Graphic I/O Card Pluggable Resistors

NOTE: Systems are shipped from the factory with 3.3K OHM resistors. Use 3.3K OHM resistors for contact monitors and 20 OHM resistors for RELAY or LED/lamp outputs.

This page intentionally left blank

3. FIELD TERMINATIONS

This section describes procedures to successfully install and terminate all field equipment that is to be terminated to the 4100 EWIS System.

3.1 SPEAKER LINE TERMINATIONS

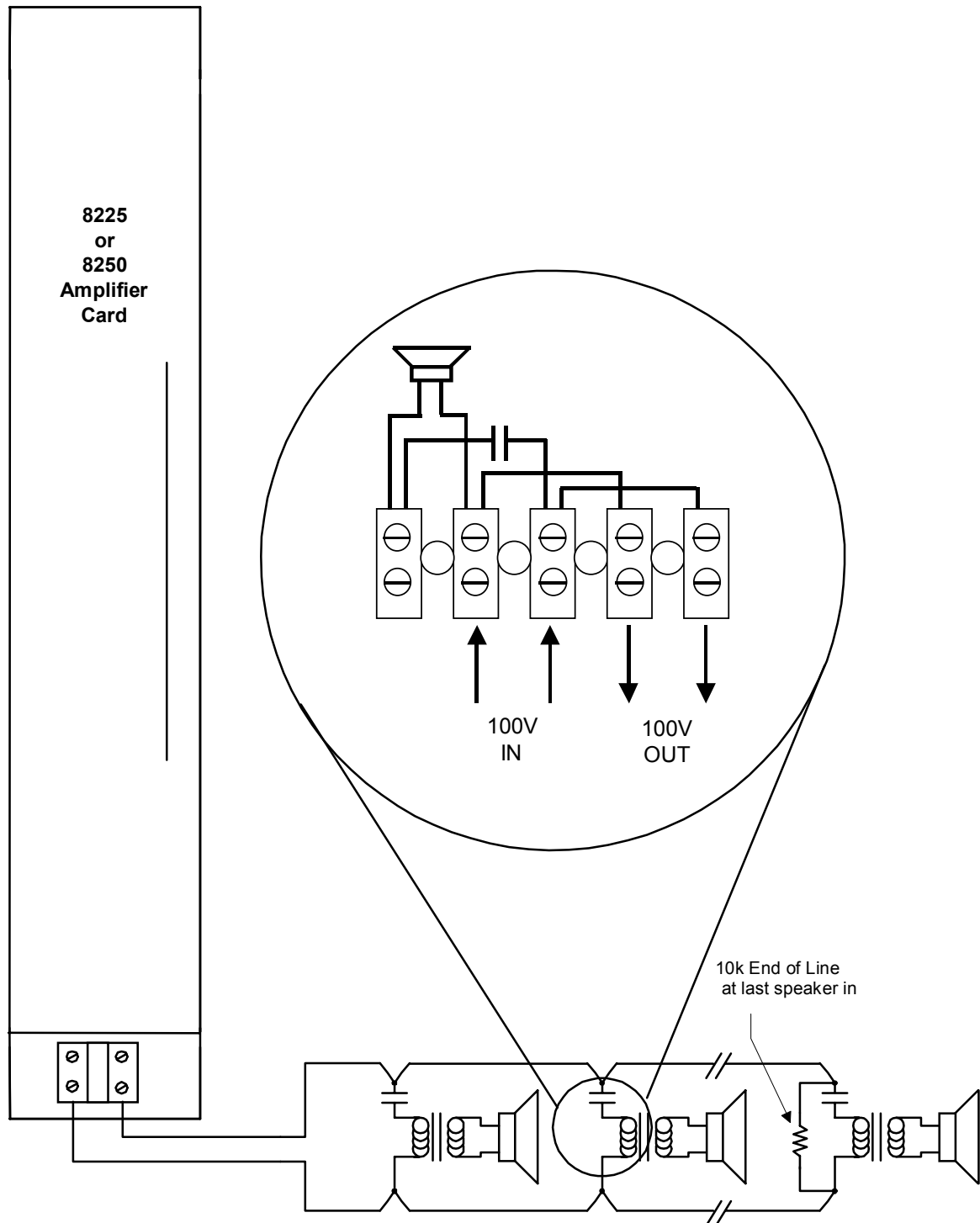

Figure 12 Amplifier Card Terminations for Speakers

Speaker lines are terminated in the 8225 or 8250 Amplifier card.

Only one Zone can be terminated on each Amplifier card, speakers can be wired in parallel, and terminated with a 10k End of Line Resistor.

The terminating connections are located at the bottom of the front panel on the amplifier card (See

Figure 12).

Speakers are terminated across the 100v output line as shown in

Figure 12.

Wiring to the speaker lines is supervised via a 10k end of line resistor placed across the last speaker in each zone.

The capacitor fly lead is connected to the transformer primary winding. Select either 0.5 W, 1 W, 2 W, or 5 W terminal for the required power output for the speaker.

3.2 EMERGENCY ALARM INITIATING DEVICES TERMINATIONS

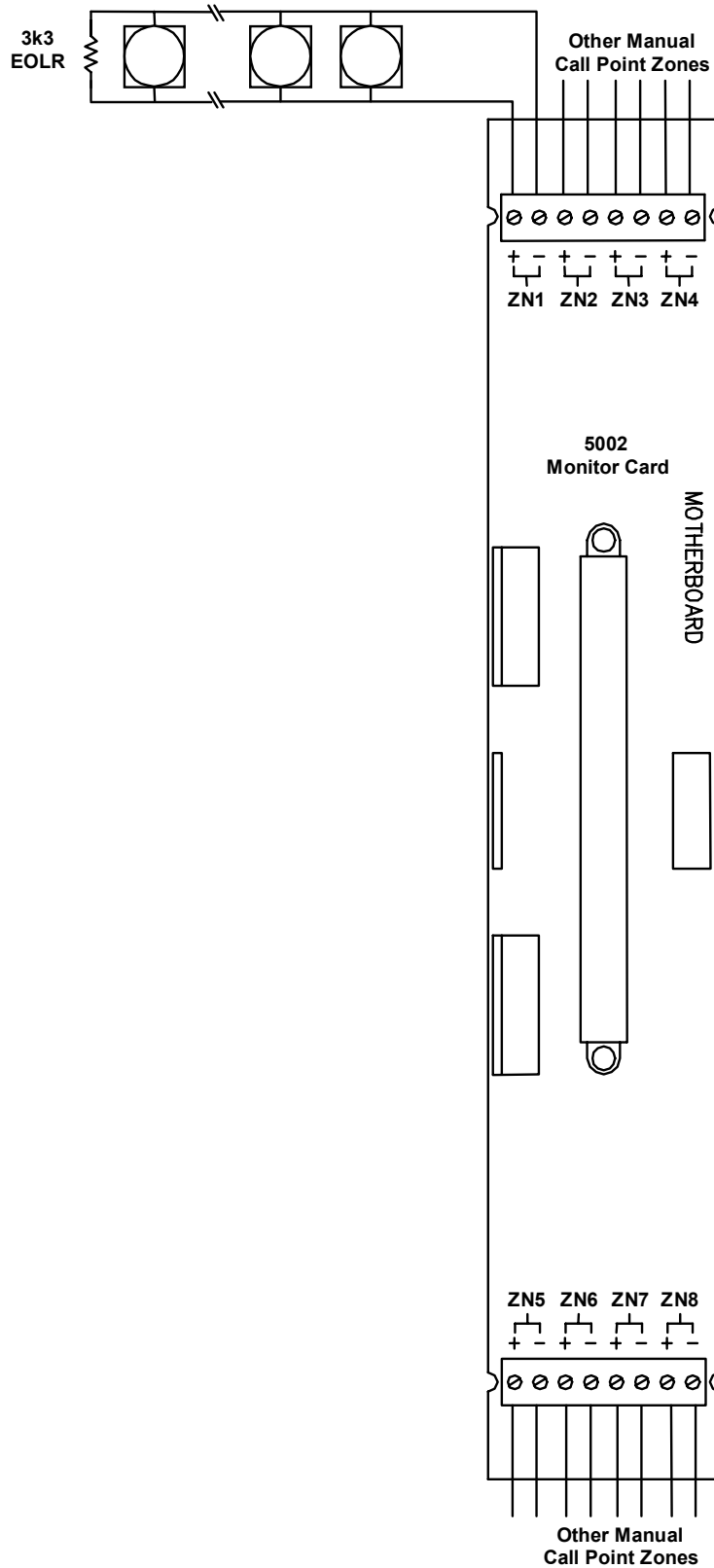

Figure 13 Monitor Card Terminations for Manual Call Points

Manual Call Points are terminated in the 4100-5002 monitor card.

There are 8 zones per card and are labelled ZN1 to ZN8 (See

Figure 13).

One Zone can terminate many Manual Call Points, but they must be wired in parallel, and terminated with a 3k3 End of Line Resistor across the last manual call point.

The terminating connections are located at the Top and Bottom of the motherboard.

3.3 FIRE INDICATOR PANEL EWIS TRIP TERMINATIONS

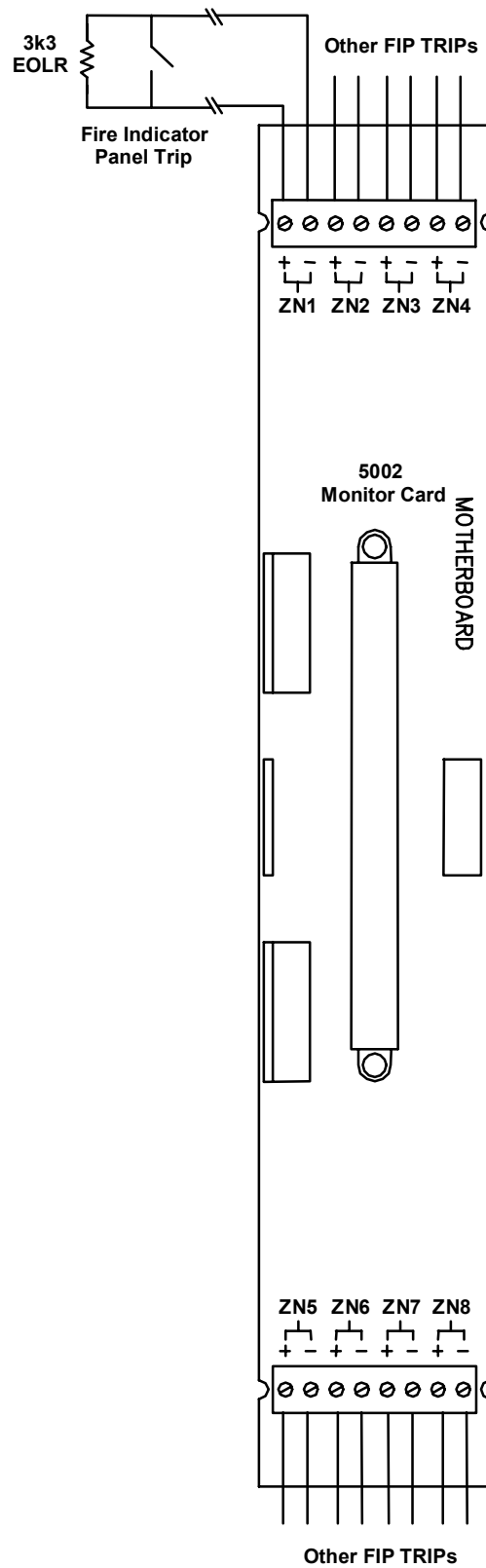

Figure 14 Monitor Card Terminations for FIP trips

The Fire Indicator Panel Trip can be terminated in the 4100-5002-monitor card.

There are 8 Input zones per card and are labelled ZN1 to ZN8 (See

Figure 14).

Each input zone monitors a set of Normally Open Contacts located in the Fire Indicator Panel and is terminated with a 3K3 End Of Line Resistor.

One of the monitor card terminations can be used.

The terminating connections are located at the Top and Bottom of the motherboard.

3.4 VISUAL ALARM DEVICE LINE TERMINATIONS

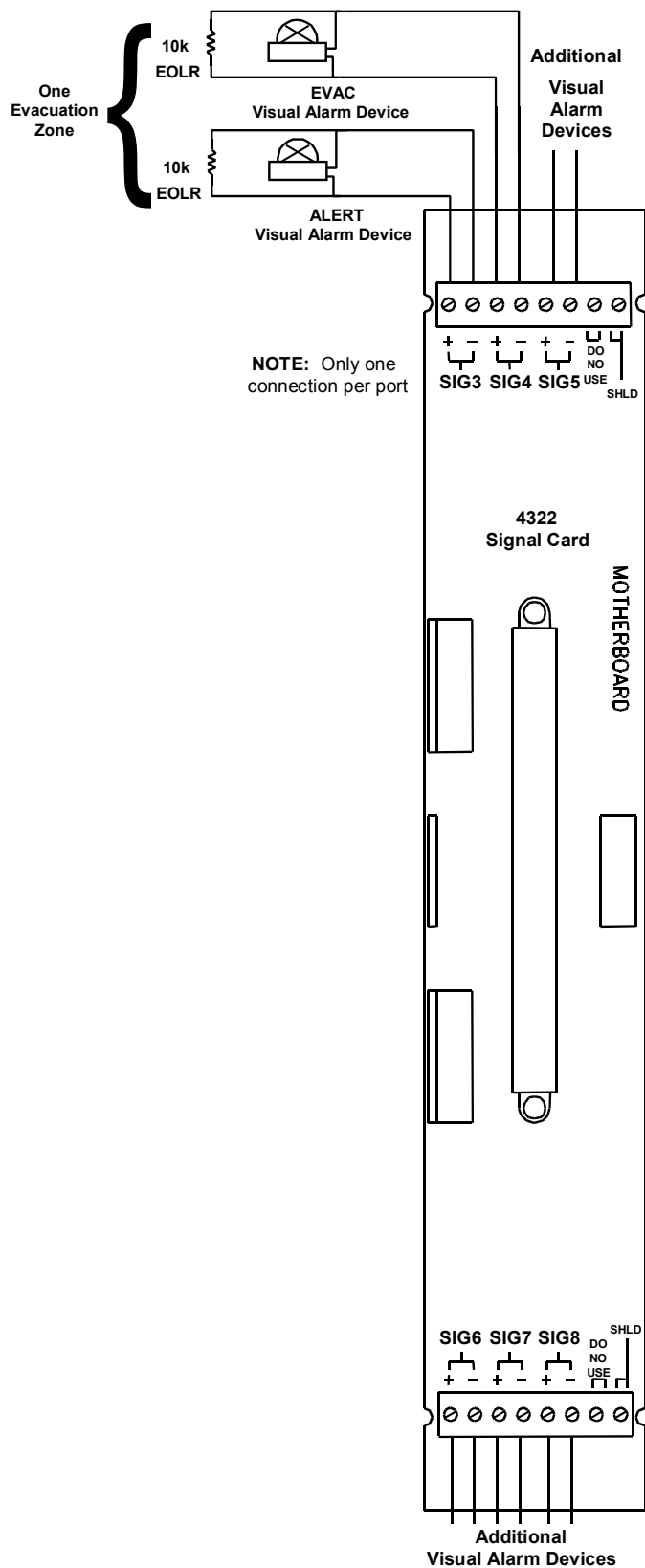

Figure 15 Signal Card Terminations for Visual Alarms Devices

Visual Alarm Devices are terminated in the 4100-4322-signal card.

There are 6 signal ports per card and are labelled SIGx to SIGx. Where x corresponds to a signal port number.

Visual Alarm Devices are terminated on each port of the signal card.

For each Evacuation Zone, two signal ports are assigned.

1. For the Alert Strobe(s)
2. For Evacuation Strobe(s)

Each Visual Alarm Device must be terminated with a 10k End of Line Resistor.

The terminating connections are located at the Top and Bottom of the motherboard.

Each port can source up to 2 Amps at 24 VDC for driving strobes.

If driving a number of strobes, ensure that the correct size cable is used to minimise voltage drop on the unit.

3.5 WIP LINE TERMINATIONS

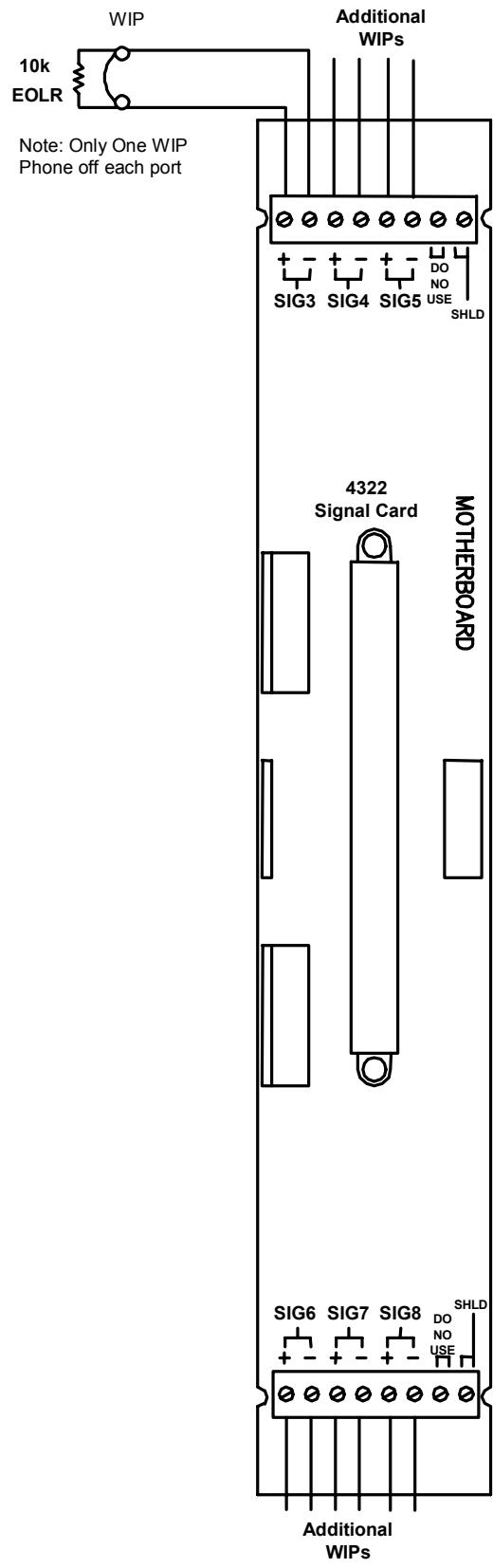

Figure 16 Signal Card Terminations for WIPs

WIP Devices are terminated in the 4100-4322-signal card.

There are 6 ports per card and are label SIG3 to SIG8. The cable shields should be connected in the termination labelled SHLD (See

Figure 16).

Only One WIP phone can be terminated on each port of the signal card. These phones must be Simplex WIP phones Part Number: - 2084-9106.

The last Each WIP phone in each zone must terminated with a 10k End of Line Resistor.

The terminating connections are located at the Top and Bottom of the motherboard.

3.6 P.A. MICROPHONE TERMINATIONS

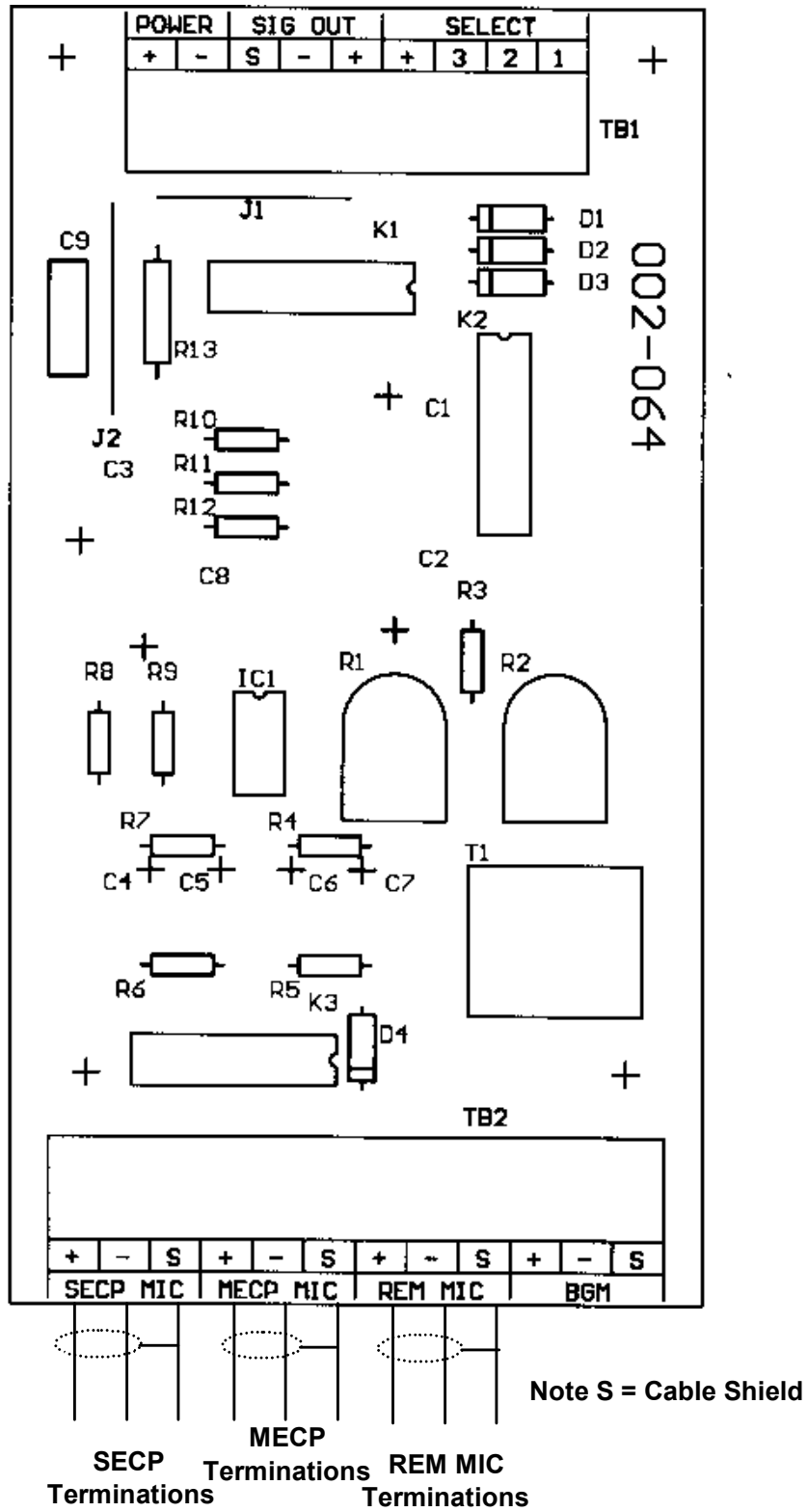

Figure 17 Pre Amplifier Board Terminations for PA

The P.A Microphone is terminated on the pre amplifier card.

The pre amplifier card is used to terminate the Master Emergency Control Point Microphone, the Secondary Emergency Control Point Microphone, and remote microphone.

The terminating connections are located at the bottom of the pre amplifier board (See

Figure 17)

3.7 BACKGROUND MUSIC TERMINATIONS

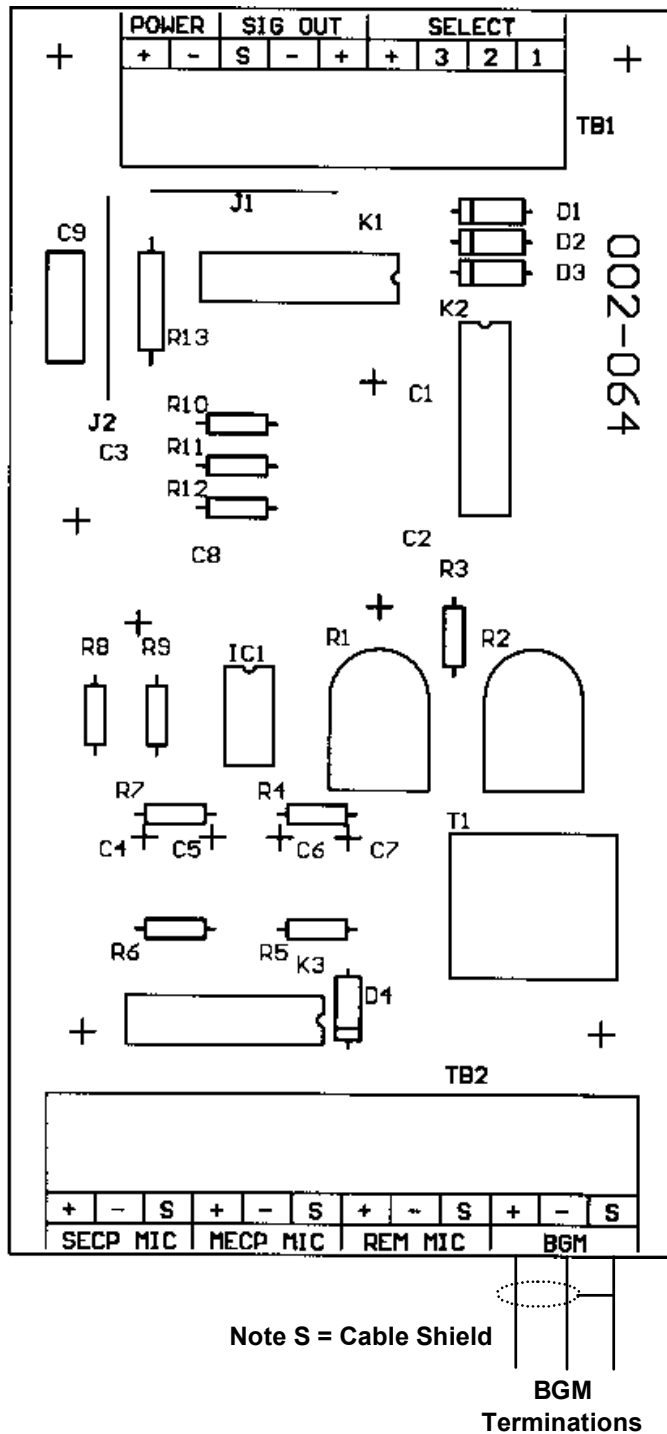

Figure 18 Pre Amplifier Board Terminations for BGM

The Background Music input is terminated on the pre amplifier card.

The terminating connections are located at the bottom of the pre amplifier board (See

Figure 18)

3.8 NETWORK WIP PHONE TERMINATION

The Network Master WIP phone is terminated on the Master Phone Assembly 4100-0205.

The Network Master WIP Phone is the start and finish of the WIP Phone Network. The WIP Phone Network leaves the master Node from port P3 and is looped through each slave node and returns to the master node on port P4. (See

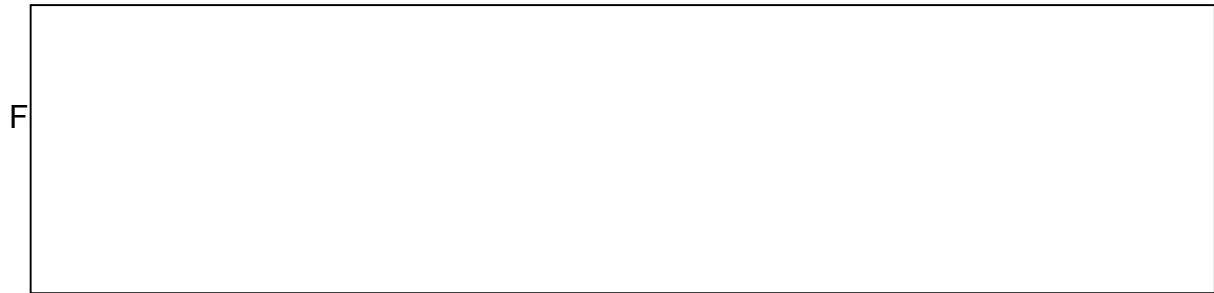

Figure 19 Master WIP Phone Network

3.8.1 Network WIP Phone Termination – Master Node

The WIP Master Phone is terminated on connector P6. Only use approved master phone part number 2084-9106.

The next node in the network is terminated on connector P4.

The last node in the network is terminated on connector P3.

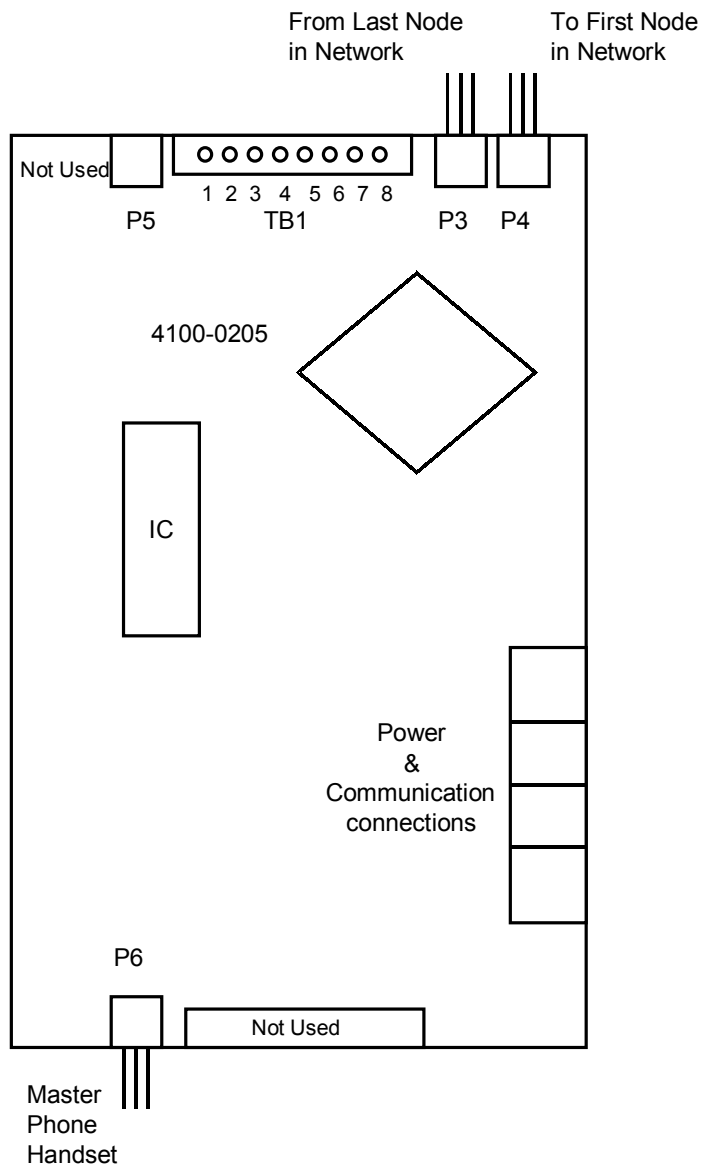

Figure 20 WIP Network Master Node Phone Terminations

The Master Phone Handset terminations are on terminals labelled 1 & 2.

The positive line on terminal 1 and the negative line on terminal 2.

3.8.2 Network WIP Phone Termination – Slave Node

The WIP Master Phone is terminated on connector P6. Only use approved master phone part number 2084-9106.

The network connections for slave node WIP Phones in the WIP Phone network are terminated on terminal block TB1 termination 7,8.

The cabling from the previous node and the next node in the network are terminated together. See

Figure 21

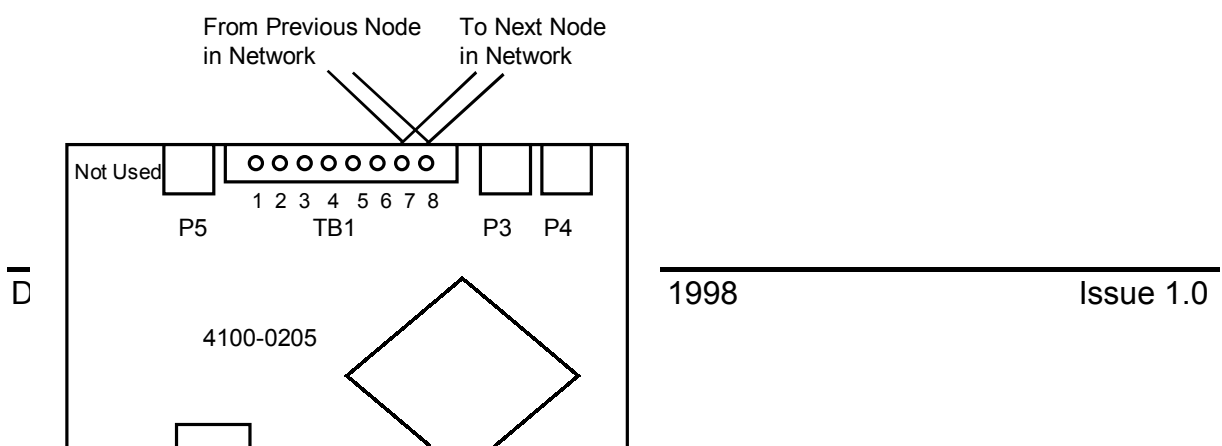

Figure 21 WIP Network Slave Node Phone Terminations

The Master Phone Handset terminations are on terminals labelled 1 & 2.

The positive line on terminal 1 and the negative line on terminal 2.

3.9 SECP TERMINATION

SECP terminations are site configuration dependent and will be designated at time of system configuration.

4 PROGRAMMERS REPORT

The Programmer's Report is used to identify peripheral connections within the panel and specifies system operational data.

The 13 sections within the Programmer's Report are shown in Tables 5 through 17, and explained in each section.

4.1 GENERAL INFORMATION

This section contains branch office required information. It details branch personnel involved with the system, system power data, agency, and software information. The software revision must match the system CFG chip label for proper operation of the LCD display.

```

-----
XYZ BUILDING                GENERAL INFORMATION                Page 1
2796 node:1 rev:6                14:41:55, WED, 25-MAR-98
-----
4100 Fire Alarm System                GENERAL
Simplex Time Recorder Co.                INFO

Node Number: 1
System Type: 4100+

      Job Filename : 2796
      Job Title   : XYZ BUILDING
      Order Number :
      Customer    :
      Customer Contact :
      Contractor  :
      Salesperson :
      Branch Number :
      Branch Location :
      Programmed by :

      Agency Approval : NONE
      NFPA Standard  : NONE
      Standby Generator? : NO
      Hours of Standby Battery :

Comments :
      :

      Job Rev : 6
      Built Rev : 6
      Built Date : 17-Mar-98 15:22

      Current      As Built
      -----
      Programmer Rev : 7.03      7.03
      System Defaults Rev : 79      79
      Database (DBF) Format : 80      80
      CFG Format : 0      0
  
```

Table 5 GENERAL INFORMATION REPORT

4.2 CARD SUMMARY BY LOCATION

The Card Summary by Location shows the number of cards within the system. This page should be used to verify delivery of system cards from the factory. It also shows a decimal card number which is the address for that printed circuit board. Addresses 3 and 9 are shown below on Custom Terminal Wiring Identifiers.

```
-----
XYZ BUILDING                CARD SUMMARY BY LOCATION                Page   3
2796 node:1 rev:6          14:41:55, WED, 25-MAR-98
```

```
-----
CARD LOCATION LISTING:
LOCAL CONTROLLER UNIT:
```

DAUGHTER CARDS:

Card	Card Type	Zone Range
0	(7003) 4100+ Master Controller	
1	(3003) 8 Pt, 3 Amp Relay w/ Feedback	AUX3-10
2	(0304) Remote Unit Interface (RUI)	RUI 1
3	(5002) 8 Zn Class B Monitor (IDC) w/Sup	ZN1-8
4	(5002) 8 Zn Class B Monitor (IDC) w/Sup	ZN9-16
5	(6005) Power Supply/Charger	
8	(5002) 8 Zn Class B Monitor (IDC) w/Sup	ZN17-24
9	(5002) 8 Zn Class B Monitor (IDC) w/Sup	ZN25-32
10	(5002) 8 Zn Class B Monitor (IDC) w/Sup	ZN33-40
11	(5002) 8 Zn Class B Monitor (IDC) w/Sup	ZN41-48
12	(5002) 8 Zn Class B Monitor (IDC) w/Sup	ZN49-56
13	(5002) 8 Zn Class B Monitor (IDC) w/Sup	ZN57-64
15	(0205) Phone Card	
19	(4332) 3 Input Class A Signal w/Sup	SIG3-8
20	(4332) 3 Input Class A Signal w/Sup	SIG9-14
21	(4332) 3 Input Class A Signal w/Sup	SIG15-20
22	(4332) 3 Input Class A Signal w/Sup	SIG21-26
23	(4332) 3 Input Class A Signal w/Sup	SIG27-32

ANNUNCIATORS:

Annun Card	Card Type	Zone Range
0	64 LED / 64 Sw Controller	
6	(0301) 64 LED / 64 Sw Controller	
7	(0301) 64 LED / 64 Sw Controller	
14	(0301) 64 LED / 64 Sw Controller	
16	(0301) 64 LED / 64 Sw Controller	
17	(0301) 64 LED / 64 Sw Controller	
18	(0301) 64 LED / 64 Sw Controller	

REMOTE UNIT INTERFACE 1 (RUI 1):

Type Unit	Card	Card Type	Zone Range
Ann	1	24 (0302) 24 Pt Graphic Interface	IO1-24
Ann	1	26 (0302) 24 Pt Graphic Interface	IO25-48
Ann	1	27 (0302) 24 Pt Graphic Interface	IO49-72
Ann	1	25 (6005) Power Supply/Charger	

Table 6 CARD SUMMARY BY LOCATION REPORT

4.3 SYSTEM POINT SUMMARY

The System Point Summary is of primary importance to the installer. Simplex personnel must provide this information prior to installation. Call your local Simplex branch office, which is listed in the Yellow Pages, and request this information be provided. This is used in conjunction with the Layout pages, to determine wiring terminations and the information shown below.

4.3.1 Zone Name

Zone names reference the custom label to specific points for actual customer wiring. They include monitor zones (ZNx), signals (SIGx), auxiliary relays (AUXx), 24 point I/O (PMx) and feedback (FBx) numbers. Zones, signals, relays, feedbacks, etc., are shown in numerical sequence.

4.3.2 Address

Each printed circuit board requires a unique address. Address 0 identifies the master termination module. Up to 119 addresses, one per printed circuit board, may be used in a system. Addresses may or may not be in sequential order, but the report always starts with address 0. Two address labels are used for each mother/daughter board combination. The mother board will have its unique address label next to the PC board connector. The daughter board will have an identical label.

4.3.3 Custom Label

The custom label identifies a location within the building or area, and contains additional information concerning each circuit. Also included with the custom label is the corresponding zone name. This ties the custom label to a zone name and allows the installer to identify where field wires are terminated, according to zone name.

Examples:	<u>1ST FLOOR SOUTH WING WIP</u>	<u>SIGNAL 2</u>
	<u>3RD FLOOR EAST WING ALERT STROBES</u>	<u>SIGNAL 40</u>

4.3.4 Point Type

This is the type of device (indicating appliance, initiating device, relays, etc.) connected to each circuit. Each device type is abbreviated. An operational description may also be included in the abbreviation.

Example:	<u>AHUM (Air Handling Unit Monitor)</u>
	<u>PRI (Primary Elevator Capture)</u>

The installer should use the System Point Summary when marking wires to the 4100 panel. These markings should include zones (ZNx+, ZNx--), signals (SIGx), etc., for each circuit within the system. Marking each wire in this matter will facilitate termination and checking of the wiring in the 4100 panel.

NOTE: The SYSTEM POINT SUMMARY Report is found within the computer printout portion of the **Factory Documentation**.

-----XYZ
BUILDING SYSTEM POINT SUMMARY Page 62796 node:1
rev:6 14:41:55, WED, 25-MAR-98

System Point Summary (ascending by zone name): POINT SUMMARY
ZONE

Zone Name	Custom Label	Device Type	Point Type	PNIS Code
SIG31	SIGNAL CARD 23 CIRCUIT SIG31		PHONE	
SIG32	SIGNAL CARD 23 CIRCUIT SIG32		PHONE	
AUX3	BATTERY TEST OUTPUT AUX3		RELAY	
AUX4	SYSTEM FAULT AUX4		RELAY	
AUX5	BRIGADE ALARM 1 AUX5		RELAY	
AUX6	BRIGADE ALARM 2 AUX6		RELAY	
AUX7	GFA OUTPUT 1 AUX7		RELAY	
AUX8	GFA OUTPUT 2 AUX8		RELAY	
AUX9	FIRE ALARM BELL AUX9		RELAY	
AUX10	SPARE AUX10		RELAY	
FB3	***** DOOR SWITCH ***** FEEDBACK PT FB3		ONOFF	
FB4	AUX RELAY CARD 4 FEEDBACK PT FB4		ONOFF	
FB5	AUX RELAY CARD 4 FEEDBACK PT FB5		ONOFF	
FB6	AUX RELAY CARD 4 FEEDBACK PT FB6		ONOFF	
FB7	AUX RELAY CARD 4 FEEDBACK PT FB7		ONOFF	
FB8	AUX RELAY CARD 4 FEEDBACK PT FB8		ONOFF	
FB9	AUX RELAY CARD 4 FEEDBACK PT FB9		ONOFF	
FB10	FIP MCP FEEDBACK PT FB10		ONOFF	
IO1	AMPLIFIER #1 HAS FAILED		TSWITCH	
IO2	AMPLIFIER #1 ALERT		RELAY	
IO3	AMPLIFIER #1 EVAC		RELAY	
IO4	AMPLIFIER #1 P.A.		RELAY	
IO5	AMPLIFIER #2 HAS FAILED		TSWITCH	
IO6	AMPLIFIER #2 ALERT		RELAY	
IO7	AMPLIFIER #2 EVAC		RELAY	
IO8	AMPLIFIER #2 P.A.		RELAY	
IO9	AMPLIFIER #3 HAS FAILED		TSWITCH	
IO10	AMPLIFIER #3 ALERT		RELAY	
IO11	AMPLIFIER #3 EVAC		RELAY	
IO12	AMPLIFIER #3 P.A.		RELAY	
IO13	AMPLIFIER #4 HAS FAILED		TSWITCH	
IO14	AMPLIFIER #4 ALERT		RELAY	
IO15	AMPLIFIER #4 EVAC		RELAY	
IO16	AMPLIFIER #4 P.A.		RELAY	
IO17	UNUSED		USWITCH	
IO18	UNUSED		USWITCH	
IO19	UNUSED		USWITCH	
IO20	UNUSED		USWITCH	
IO21	UNUSED		USWITCH	
IO22	UNUSED		USWITCH	
IO23	UNUSED		USWITCH	
IO24	UNUSED		USWITCH	
IO25	AMPLIFIER #5 HAS FAILED		TSWITCH	
IO26	AMPLIFIER #5 ALERT		RELAY	
IO27	AMPLIFIER #5 EVAC		RELAY	
IO28	AMPLIFIER #5 P.A.		RELAY	

Table 7 SYSTEM POINT SUMMARY REPORT

NOTES:

- A. Custom label information tells you where the circuit goes.
- B. At both ends of each circuit, tag wires with zone name and polarity (in cases where polarity applies).
 - For example, SIG 3+ and SIG 3-.

4.4 SYSTEM OPTION SUMMARY

The System Options Summary lists all standard system operations. Enabled operations are shown with the word "YES".

```

-----
XYZ BUILDING                      SYSTEM OPERATION                      Page 2
2796 node:1 rev:6                14:41:55, WED, 25-MAR-98
-----
                                           OPTIONS
                                           SUMMARY

Standard System Operations  Enabled?  Settings
-----
Alarm Silence Inhibit..... NO
Time Limit Signal Control... NO
System Trouble Reminder.... NO
Dedicated Waterflow Signals. NO
Sprinkler Supv. Operation... NO
Alarm Verification Setup.... NO
Individual Acknowledge ..... NO      GLOBAL
Elevator Recall Operation... NO
Non-Steady Audible Evac Sig. NO
Non-Steady Visual Evac Sig. NO
Door Holder Operation..... NO

Expanded System Operations  Enabled?  Settings
-----
24-Hr Time/Date Format..... NO      12 HOUR
Coding Group Configuration.. NO
Audio Coding Configuration.. NO
Audio Option Configuration.. NO
Walk Test by Group..... NO
Non-General Alarm Operation. NO
Pre-Programmed User Lists... YES      *
Temperature in Centigrade... NO      FAHRENHEIT
Default Local Mode..... YES
Paging Channel Selection.... NO

Other Selections            Enabled?  Settings
-----
Access Levels              *
Non-Default Passcodes     NO
City Connect              Form 'C' Dry Contact
Custom Control            YES      Program: 3, 4, 5, 7
  
```

* Operation ENABLED. See Options Detail Report for full description.

Table 8 SYSTEM OPTIONS SUMMARY

4.5 UNIT DETAIL REPORT

The Unit Detail Report shows detailed information regarding each printed circuit board as well as software cards (pseudos) in the system. Custom information is shown for each type of card, such as card number, card address (binary), circuits on the card, circuit types, custom labels, and coding information, if applicable.

```
-----
XYZ BUILDING                               UNIT DETAIL REPORT                       Page 62
2796 node:1 rev:6                          14:41:55, WED, 25-MAR-98
```

```
-----
UNIT No: 0                                UNIT 0
CARD No: 0 (base)                          0-4
64 LED / 64 Sw Controller
```

CONTROL PANEL LED/SWITCH ANNUNCIATOR 0

UNIT COMPOSITION:

Card No	Card Type	Display Card Point Usage
0	64 LED / 64 Sw Controller	0 LEDs / 0 SWs
6	(0301) 64 LED / 64 Sw Controller	64 LEDs / 32 SWs
7	(0301) 64 LED / 64 Sw Controller	64 LEDs / 40 SWs
14	(0301) 64 LED / 64 Sw Controller	64 LEDs / 40 SWs
16	(0301) 64 LED / 64 Sw Controller	64 LEDs / 40 SWs
17	(0301) 64 LED / 64 Sw Controller	64 LEDs / 32 SWs
18	(0301) 64 LED / 64 Sw Controller	0 LEDs / 0 SWs
1	(3003) 8 Pt, 3 Amp Relay w/ Feedback	N/A
2	(0304) Remote Unit Interface (RUI)	N/A
3	(5002) 8 Zn Class B Monitor (IDC) w/Sup	N/A
4	(5002) 8 Zn Class B Monitor (IDC) w/Sup	N/A
5	(6005) Power Supply/Charger	N/A
8	(5002) 8 Zn Class B Monitor (IDC) w/Sup	N/A
9	(5002) 8 Zn Class B Monitor (IDC) w/Sup	N/A
10	(5002) 8 Zn Class B Monitor (IDC) w/Sup	N/A
11	(5002) 8 Zn Class B Monitor (IDC) w/Sup	N/A
12	(5002) 8 Zn Class B Monitor (IDC) w/Sup	N/A
13	(5002) 8 Zn Class B Monitor (IDC) w/Sup	N/A
19	(4332) 3 Input Class A Signal w/Sup	N/A
20	(4332) 3 Input Class A Signal w/Sup	N/A
21	(4332) 3 Input Class A Signal w/Sup	N/A
22	(4332) 3 Input Class A Signal w/Sup	N/A
23	(4332) 3 Input Class A Signal w/Sup	N/A

NOTE: Card 0, Annun 0 = Master Controller slot 4

Table 9 UNIT DETAIL REPORT

4.6 ANNUNCIATOR REPORT

The Local Annunciator Report is shown first (if applicable), followed by the Remote Annunciator Report (if applicable). The first page of these reports shows the controller/card number, position, and the type of display cards selected. The next pages will show the point, switch mode, reference address, reference custom label, and the reference type. A typical Local Annunciator Report is shown in Figure 7.

```

-----
XYZ BUILDING 1                      CARD DETAIL REPORT                      Page 11
909015J node:1 rev:1                04:39:17, WED, 14-MAY-97
-----
CARD No:    5                                LED/SW
(0301) 64 LED / 64 Sw Controller          CARD
UNIT No:    0                                5
  
```

```

addr 00000101
sw1 12345678
  
```

CONTROLLER CARD CONFIGURATION DETAIL:

Controller Card No	Display Card	Display Card Type
5	1	L403 - 8 Momen Sw/8 Red LED
	2	L405 - 8 Momen Sw/16 Red-Yel LED
	3	L405 - 8 Momen Sw/16 Red-Yel LED
	4	L405 - 8 Momen Sw/16 Red-Yel LED
	5	0409 - Blank Display Card
	6	0409 - Blank Display Card
	7	0409 - Blank Display Card
	8	0102 - Battery Meters (amp/volt)
	9	0409 - Blank Display Card
	10	0409 - Blank Display Card
	11	0409 - Blank Display Card
	12	0409 - Blank Display Card
	13	0409 - Blank Display Card
	14	0409 - Blank Display Card
	15	0409 - Blank Display Card
	16	0409 - Blank Display Card

Table 10 LOCAL ANNUNCIATOR REPORT

4.7 DIGITAL PSEUDO POINT SUMMARY

The Digital Pseudo Point Summary shows all digital pseudo points within the system. It also identifies the custom labels, and pseudo type for each digital pseudo point within the system.

```

-----
XYZ BUILDING          DIGITAL PSEUDO POINT SUMMARY          Page 20
2796 node:1 rev:6    14:41:55, WED, 25-MAR-98
-----
CARD No: 132          DIGITAL SUMMARY
256 Point Digital Pseudo          P1024 - P1075

```

Point	Custom Label	Type	PNIS Codes
P1024	KEYSWITCH - AUTO	UTILITY	
P1025	E.W.S KEYSWITCH IN MANUAL POSITION	TROUBLE	
P1026	E.W.S KEYSWITCH IN ISOLATE POSITION	SUPERV	
P1027	KEYSWITCH - AUTO LED	UTILITY	
P1028	ALL ALERT - MANUAL	UTILITY	
P1029	ALL EVAC - MANUAL	UTILITY	
P1030	ALL P.A. - MANUAL	UTILITY	
P1031	ALL CANCEL - MANUAL	UTILITY	
P1033	ALL ALERT LED	UTILITY	
P1034	ALL EVAC LED	UTILITY	
P1035	ALL P.A. LED	UTILITY	
P1036	ENABLE CASCADE OPERATION	UTILITY	
P1037	ALL CALL - RING THE PHONES	UTILITY	
P1038	ALL CALL - TALK TO ALL PHONES	UTILITY	
P1040	AMP 1 FAULT LED	UTILITY	
P1041	AMP 2 FAULT LED	UTILITY	
P1042	AMP 3 FAULT LED	UTILITY	
P1043	AMP 4 FAULT LED	UTILITY	
P1044	AMP 5 FAULT LED	UTILITY	
P1045	AMP 6 FAULT LED	UTILITY	
P1046	AMP 7 FAULT LED	UTILITY	
P1047	AMP 8 FAULT LED	UTILITY	
P1048	AMP 9 FAULT LED	UTILITY	
P1049	AMP 10 FAULT LED	UTILITY	
P1050	AMP 11 FAULT LED	UTILITY	
P1051	AMP 12 FAULT LED	UTILITY	
P1052	AMP 13 FAULT LED	UTILITY	
P1053	AMP 14 FAULT LED	UTILITY	
P1054	AMP 15 FAULT LED	UTILITY	
P1055	AMP 16 FAULT LED	UTILITY	
P1060	SPEAKER LINE SHORTED - AMP #1 DISABLED	TROUBLE	
P1061	SPEAKER LINE OPEN CIRCUIT - AMPLIFIER #1	TROUBLE	
P1062	SPEAKER LINE SHORTED - AMP #2 DISABLED	TROUBLE	
P1063	SPEAKER LINE OPEN CIRCUIT - AMPLIFIER #2	TROUBLE	
P1064	SPEAKER LINE SHORTED - AMP #3 DISABLED	TROUBLE	
P1065	SPEAKER LINE OPEN CIRCUIT - AMPLIFIER #3	TROUBLE	
P1066	SPEAKER LINE SHORTED - AMP #4 DISABLED	TROUBLE	
P1067	SPEAKER LINE OPEN CIRCUIT - AMPLIFIER #4	TROUBLE	
P1068	SPEAKER LINE SHORTED - AMP #5 DISABLED	TROUBLE	
P1069	SPEAKER LINE OPEN CIRCUIT - AMPLIFIER #5	TROUBLE	
P1070	SPEAKER LINE SHORTED - AMP #6 DISABLED	TROUBLE	
P1071	SPEAKER LINE OPEN CIRCUIT - AMPLIFIER #6	TROUBLE	
P1072	SPEAKER LINE SHORTED - AMP #7 DISABLED	TROUBLE	
P1073	SPEAKER LINE OPEN CIRCUIT - AMPLIFIER #7	TROUBLE	
P1074	SPEAKER LINE SHORTED - AMP #8 DISABLED	TROUBLE	
P1075	SPEAKER LINE OPEN CIRCUIT - AMPLIFIER #8	TROUBLE	

Table 11 DIGITAL PSEUDO POINT SUMMARY

4.8 ANALOG PSEUDO POINT SUMMARY

The Analog Pseudo Point Summary shows all analog pseudo points within the system. It also identifies the custom labels and pseudo type for each analog pseudo point within the system.

```

-----
XYZ BUILDING                ANALOG PSEUDO POINT SUMMARY                Page 28
2796 node:1 rev:6          14:41:55, WED, 25-MAR-98
-----
CARD No: 145                ANALOG SUMMARY
256 Point Analog Pseudo    A256 - A283
  
```

Point	Custom Label	Type
A257	CUSTOM CONTROL - TIMER	TIMER
A258	CUSTOM CONTROL - TIMER	TIMER
A259	CUSTOM CONTROL - TIMER	TIMER
A260	CUSTOM CONTROL - TIMER	TIMER
A261	CUSTOM CONTROL - TIMER	TIMER
A262	CUSTOM CONTROL - TIMER	TIMER
A263	CUSTOM CONTROL - TIMER	TIMER
A264	RESET MESSAGE TIMER 1	TIMER
A265	RESET MESSAGE TIMER 2	TIMER
A266	RESET MESSAGE TIMER 3	TIMER
A267	ALERT/EVAC CHANGEOVER VALUE	ANALOG
A268	ZN 1 AL/EV TIMER	TIMER
A269	ZN 2 AL/EV TIMER	TIMER
A270	ZN 3 AL/EV TIMER	TIMER
A271	ZN 4 AL/EV TIMER	TIMER
A272	ZN 5 AL/EV TIMER	TIMER
A273	ZN 6 AL/EV TIMER	TIMER
A274	ZN 7 AL/EV TIMER	TIMER
A275	ZN 8 AL/EV TIMER	TIMER
A276	ZN 9 AL/EV TIMER	TIMER
A277	ZN 10 AL/EV TIMER	TIMER
A278	ZN 11 AL/EV TIMER	TIMER
A279	ZN 12 AL/EV TIMER	TIMER
A280	ZN 13 AL/EV TIMER	TIMER
A281	ZN 14 AL/EV TIMER	TIMER
A282	ZN 15 AL/EV TIMER	TIMER
A283	ZN 16 AL/EV TIMER	TIMER

Table 12 ANALOG PSEUDO POINT SUMMARY

4.9 Point List Summary

The Point List Summary identifies the number of pseudo lists within the system. These lists are in numerical sequence, contain a description, and identify the number of points within each list.

```
-----
XYZ BUILDING                POINT LIST SUMMARY                Page 31
2796 node:1 rev:6          14:41:55, WED, 25-MAR-98
```

```
-----
CARD No: 160                POINT LIST
256 Point List Pseudo      L86 - L145
```

continued

List Name	Description	Points
L86	RESTART MESSAGE AFTER MIKE - VTG 2	EMPTY
L87	AHU RELAYS ON - ON FIRE ALARM	EMPTY
L88	AHU RELAYS OFF - ON FIRE ALARM	EMPTY
L89	AHU RELAYS OFF - ON SYSTEM RESET	EMPTY
L90	ALL SPEAKERS - NON EDITABLE	EMPTY
L91	AUDIO CODING GROUP 1 - SIGNAL CIRCUITS	EMPTY
L92	AUDIO CODING GROUP 2 - SIGNAL CIRCUITS	EMPTY
L93	PHONE CIRCUITS	30
L94	REMOTE MASTER PHONE CIRCUITS	EMPTY
L95	SATELLITE PHONES - SCC 4100 ON/OFF	EMPTY
L96	SATELLITE PHONES - SCC 4100 NORMAL/SHORT	EMPTY
L97	SATELLITE PHONES - SCC 4100 ON/OFF RMPH	EMPTY
L98	SWITCH POWER SUPPLY AMPS TO BATTERY	2
L99	SWITCH POWER SUPPLY AMPS TO BKGRND MUSIC	2
L100	POINTS TO EXCLUDE FROM AUTOMAP	EMPTY
L101	RESET POWER SUPPLY AMPS	2
L102	LISTS TO AUTO-GENERATE EXTERNAL POINTS	21
L103	EXTERNAL DETECTOR RESET PSEUDO	EMPTY
L104	EXTERNAL SYSTEM RESET PSEUDO	EMPTY
L105	EXTERNAL DETECTOR/SYSTEM RESET PSEUDO	EMPTY
L106	EXTERNAL SIGNAL SILENCE PSEUDO	EMPTY
L107	ENTER LOCAL MODE ON DATA NOT AVAILABLE	EMPTY
L108	EXTERNAL SPEAKERS AND SPEAKER LISTS	EMPTY
L109	ALARM SILENCED LED CONTROL	EMPTY
L112	EXTERNAL PRIORITY 2 RESET PSEUDOS	EMPTY
L128	BRIGADE ALARM 1 LIST (PFA)	EMPTY
L129	BRIGADE ALARM 2 LIST (VMD)	EMPTY
L130	AMP 1 FIRE TRIP LIST	1
L131	AMP 2 FIRE TRIP LIST	1
L132	AMP 3 FIRE TRIP LIST	1
L133	AMP 4 FIRE TRIP LIST	1
L134	AMP 5 FIRE TRIP LIST	1
L135	AMP 6 FIRE TRIP LIST	1
L136	AMP 7 FIRE TRIP LIST	1
L137	AMP 8 FIRE TRIP LIST	1
L138	AMP 9 FIRE TRIP LIST	1
L139	AMP 10 FIRE TRIP LIST	1
L140	AMP 11 FIRE TRIP LIST	1
L141	AMP 12 FIRE TRIP LIST	1
L142	AMP 13 FIRE TRIP LIST	1
L143	AMP 14 FIRE TRIP LIST	1
L144	AMP 15 FIRE TRIP LIST	1
L145	AMP 16 FIRE TRIP LIST	1

NOTE: * Indicates Auto List Generation disabled for system list.

Table 13 POINT LIST SUMMARY

4.10 POINT LIST DETAIL

The Point List Detail identifies each list (with points identified) within the Point List Summary. It shows the list number, points within the list, custom point labels, and type of device connected to the circuit.

```

-----
XYZ BUILDING                                POINT LIST DETAIL                                Page 32
2796 node:1 rev:6                          14:41:55, WED, 25-MAR-98
-----
CARD No: 160    L18                                POINT LIST
256 Point List Pseudo
LIST No: 18                                          L18
                                                    continued

Description: GENERAL FIRE ALARM MONITOR ZONES

Point      Custom Point Label      Device Point
-----
ZN1        MONITOR CARD 3 ZONE NUMBER 1      MONB  FIRE
ZN2        MONITOR CARD 3 ZONE NUMBER 2      MONB  FIRE
ZN3        MONITOR CARD 3 ZONE NUMBER 3      MONB  FIRE
ZN4        MONITOR CARD 3 ZONE NUMBER 4      MONB  FIRE
ZN5        MONITOR CARD 3 ZONE NUMBER 5      MONB  FIRE
ZN6        MONITOR CARD 3 ZONE NUMBER 6      MONB  FIRE
ZN7        MONITOR CARD 3 ZONE NUMBER 7      MONB  FIRE
ZN8        MONITOR CARD 3 ZONE NUMBER 8      MONB  FIRE
ZN9        MONITOR CARD 4 ZONE NUMBER 9      MONB  FIRE
ZN10       MONITOR CARD 4 ZONE NUMBER 10     MONB  FIRE
ZN11       MONITOR CARD 4 ZONE NUMBER 11     MONB  FIRE
ZN12       MONITOR CARD 4 ZONE NUMBER 12     MONB  FIRE
ZN13       MONITOR CARD 4 ZONE NUMBER 13     MONB  FIRE
ZN14       MONITOR CARD 4 ZONE NUMBER 14     MONB  FIRE
ZN15       MONITOR CARD 4 ZONE NUMBER 15     MONB  FIRE
ZN16       MONITOR CARD 4 ZONE NUMBER 16     MONB  FIRE
ZN17       MONITOR CARD 8 ZONE NUMBER 17     MONB  FIRE
ZN18       MONITOR CARD 8 ZONE NUMBER 18     MONB  FIRE
ZN19       MONITOR CARD 8 ZONE NUMBER 19     MONB  FIRE
ZN20       MONITOR CARD 8 ZONE NUMBER 20     MONB  FIRE
ZN21       MONITOR CARD 8 ZONE NUMBER 21     MONB  FIRE
ZN22       MONITOR CARD 8 ZONE NUMBER 22     MONB  FIRE
ZN23       MONITOR CARD 8 ZONE NUMBER 23     MONB  FIRE
ZN24       MONITOR CARD 8 ZONE NUMBER 24     MONB  FIRE
ZN25       MONITOR CARD 9 ZONE NUMBER 25     MONB  FIRE
ZN26       MONITOR CARD 9 ZONE NUMBER 26     MONB  FIRE
ZN27       MONITOR CARD 9 ZONE NUMBER 27     MONB  FIRE
ZN28       MONITOR CARD 9 ZONE NUMBER 28     MONB  FIRE
ZN29       MONITOR CARD 9 ZONE NUMBER 29     MONB  FIRE
ZN30       MONITOR CARD 9 ZONE NUMBER 30     MONB  FIRE
ZN31       MONITOR CARD 9 ZONE NUMBER 31     MONB  FIRE
ZN32       MONITOR CARD 9 ZONE NUMBER 32     MONB  FIRE
ZN33       MONITOR CARD 10 ZONE NUMBER 33    MONB  FIRE
ZN34       MONITOR CARD 10 ZONE NUMBER 34    MONB  FIRE
ZN35       MONITOR CARD 10 ZONE NUMBER 35    MONB  FIRE
ZN36       MONITOR CARD 10 ZONE NUMBER 36    MONB  FIRE
ZN37       MONITOR CARD 10 ZONE NUMBER 37    MONB  FIRE
ZN38       MONITOR CARD 10 ZONE NUMBER 38    MONB  FIRE
ZN39       MONITOR CARD 10 ZONE NUMBER 39    MONB  FIRE
ZN40       MONITOR CARD 10 ZONE NUMBER 40    MONB  FIRE
ZN41       MONITOR CARD 11 ZONE NUMBER 41    MONB  FIRE
ZN42       MONITOR CARD 11 ZONE NUMBER 42    MONB  FIRE
  
```

Table 14 POINT LIST DETAIL

4.11 OPTIONS DETAIL REPORT

The Options Detail Report specifies the options selected for the system. Also included in this report is a list of the passcode assignment levels for the various system functions.

```
-----
XYZ BUILDING                OPTIONS DETAIL REPORT                Page 99
2796 node:1 rev:6          14:41:55, WED, 25-MAR-98
```

```
-----
                                OPTIONS
                                PASSCODES
```

Display Function	Protection Level
Alarm Silence	1
System Reset	1
Change Time and Date	1
Panel Control Key 1	1
Panel Control Key 2	1
Panel Control Key 3	1
Panel Control Key 4	1
Panel Control Key 5	1
ON/OFF/AUTO Keys	1
ARM/DISARM Keys	1
Change TrueAlarm Sensitivities	3
DISABLE/ENABLE Keys	3
Clear Trouble Log	3
Clear Alarm Log	3
Enter/exit Walk Test mode	3
Clear Alarm Verification tallies	3
* Fire Alarm Acknowledge	1
* Priority 2 Acknowledge	1
* Supervisory Acknowledge	1
* Trouble Acknowledge	1
* Alarm List/Display Time	1
* Change Point Status	4
* Run Diagnostics	4
* Display Diagnostics	3
* Remote Download	4
* Display Idle Time	4
* Memory Access	4

NOTE: * Indicates protected functions not on order sheet.

```
PROTECTION SCALE
Level 1 - Lo
Level 4 - Hi
```

Table 15 OPTIONS DETAIL REPORT

4.12 NETWORK INTERFACE REPORT

The Network Interface Report specifies the network points associated with the node and identifies them as either Public Points or External Points (points referenced from other nodes).

 XYZ BUILDING 1 NETWORK INTERFACE REPORT Page 154
 909015J node:1 rev:1 5:20:54, THU, 08-MAY-97

Network Node : 1
 Network Filename : SXNET
 Master Timekeeper : YES
 Annunciate Missing Node : YES

Pt	Typ	Point Name	Device Type	Point Type	Custom Label
1	PUB	1:1	COMNTBL	TROUBLE	COMMON TROUBLE POINT FOR NODE: 1
2	PUB	P210	DIGITAL	UTILITY	NETWORK DETECTOR RESET
3	PUB	P211	DIGITAL	UTILITY	NETWORK SYSTEM RESET
4	PUB	P212	DIGITAL	UTILITY	DETECTOR/SYSTEM RESET
5	PUB	P217	DIGITAL	UTILITY	NETWORK SIGNAL SILENCE
6	PUB	P132	DIGITAL	TROUBLE	ANALOG SENSOR ALMOST DIRTY LOG ENABLE
7	PUB	P134	DIGITAL	TROUBLE	CLEAR ANALOG SENSOR PEAK VALUE
8	PUB	P214	DIGITAL	TROUBLE	CLEAR VERIFICATION TALLIES
9	PUB	P187	DIGITAL	UTILITY	VTG & AMPLIFIER TROUBLE DISABLE
10	PUB	P47	DIGITAL	UTILITY	SIGNALS/VISUALS ACTIVE
11	PUB	P85	DIGITAL	UTILITY	VTG 1 - ACTIVE
12	PUB	P220	DIGITAL	UTILITY	NETWORK PRIORITY 2 RESET
13	PUB	P221	DIGITAL	UTILITY	SIGNALS ACTIVE - OFF ON SILENCE
14	PUB	P204	DIGITAL	UTILITY	SIGNALS SILENCED
256	EXT	2:1	COMNTBL	TROUBLE	COMMON TROUBLE POINT FOR NODE: 2
512	EXT	2:P601	DIGITAL	UTILITY	M1-1 ALARM
513	EXT	2:P602	DIGITAL	UTILITY	M1-2 ALARM
514	EXT	2:P603	DIGITAL	UTILITY	M1-3 ALARM
515	EXT	2:P604	DIGITAL	UTILITY	M1-4 ALARM
516	EXT	2:P605	DIGITAL	UTILITY	M1-5 ALARM
517	EXT	2:P606	DIGITAL	UTILITY	M1-6 ALARM
518	EXT	2:P607	DIGITAL	UTILITY	M1-7 ALARM
519	EXT	2:P608	DIGITAL	UTILITY	M1-8 ALARM
520	EXT	2:P609	DIGITAL	UTILITY	M1-9 ALARM
521	EXT	2:P610	DIGITAL	UTILITY	M1-10 ALARM
522	EXT	2:P611	DIGITAL	UTILITY	M1-11 ALARM
523	EXT	2:P612	DIGITAL	UTILITY	M1-12 ALARM
524	EXT	2:P613	DIGITAL	UTILITY	M1-13 ALARM
525	EXT	2:P614	DIGITAL	UTILITY	M1-14 ALARM
526	EXT	2:P615	DIGITAL	UTILITY	M1-15 ALARM
527	EXT	2:P616	DIGITAL	UTILITY	M1-16 ALARM
528	EXT	2:P617	DIGITAL	UTILITY	M1-17 ALARM
529	EXT	2:P618	DIGITAL	UTILITY	M1-18 ALARM
530	EXT	2:P619	DIGITAL	UTILITY	M1-19 ALARM
531	EXT	2:P620	DIGITAL	UTILITY	M1-20 ALARM
532	EXT	2:P621	DIGITAL	UTILITY	M1-21 ALARM
533	EXT	2:P622	DIGITAL	UTILITY	M1-22 ALARM

Table 16 NETWORK INTERFACE REPORT

4.13 CUSTOM CONTROL EQUATION LISTING

The Custom Control Equation Listing displays the line by line Custom Control equations for the system.

```

-----
XYZ BUILDING                CUSTOM CONTROL EQUATION LISTING                Page 156
2796 node:1 rev:6                14:41:55, WED, 25-MAR-98
-----
                                CUSTOM CONTROL
                                EQU DETAIL

Program: 7                                Program: 7

Label: AUTO LED                                Equation 1

  COMMENTS:
  INPUTS:
    OR the ON state of:
      P1024      UTILITY      KEYSWITCH - AUTO
      P2         UTILITY      FRONT PANEL LAMPTEST CONTROL (ANNUNC. 0)
      P1027      UTILITY      KEYSWITCH - AUTO LED
  OUTPUTS:
    TRACK points ON pri=9,9
      16-152     UTILITY      Ann 0 Pt 152 LED/SW Spec Output
  END:

Label: ALERT/EVAC DELAY - NORMAL - 10 MINS                Equation 2

  COMMENTS:
  AS 2220.1 STATES THE DELAY BETWEEN ALERT AND EVAC MUST NOT EXCEED 10
  MINUTES
  INPUTS:
    NOT the ON state of:
      P5         UTILITY      SET SERVICE PSEUDO VALUES
  OUTPUTS:
    SET to value 600 (Secs) the analogs:
      A267      ANALOG      ALERT/EVAC CHANGEOVER VALUE
  END:

Label: ALERT/EVAC DELAY - SERVICE - 15 SECS                Equation 3

  COMMENTS:
  INPUTS:
    The ON state of:
      P5         UTILITY      SET SERVICE PSEUDO VALUES
  OUTPUTS:
    SET to value 15 (Secs) the analogs:
      A267      ANALOG      ALERT/EVAC CHANGEOVER VALUE
  END:

Label: * ENABLE alert/evac/cascade OPERATION *                Equation 4

  COMMENTS:
  INPUTS:
    The ON state of:
      A34      TIMER      SYSTEM STARTUP PULSE TIMER
  OUTPUTS:
    HOLD points ON pri=9,9
      P1036     UTILITY      ENABLE CASCADE OPERATION

```

Table 17 CUSTOM CONTROL EQUATION LISTING

5. PLACING SYSTEM INTO OPERATION

Before undertaking any activities inspect the interior visually and check that all panel equipment is securely mounted, and that all cables are connected at the appropriate points.

5.1 POWER UP PROCEDURES

When power is first applied to the panel, or when the processor has been reset, the system will self-test the integrity of its memory and verify proper card installation. At the end of the self-test, the system will display "SYSTEM STARTUP IN PROGRESS" followed by at least two fault conditions (battery and time and date). After the battery is connected and the time and date has been entered, the system should then display the message "SYSTEM IS NORMAL" along with the time and date.

Notes:

- (i) When a printed circuit board is not properly inserted, the system will display a fault condition.
- (ii) When a printed circuit board is inserted, but configured incorrectly or not defined in software, the system will display a fault condition, normal operation will be suspended for that card until the fault has been corrected.
- (iii) Other failures will cause a message to be displayed to the operator, may cause the system to become inoperative and the tone alert to sound continuously.
Refer Appendix A for a list of Fault Messages and likely causes and rectification

To power up the 4100 system, perform the following steps:

- (a) Ensure that the mains isolate switch is OFF and batteries are disconnected. Ensure that 240V AC supply is connected to the panel from the mains distribution board.
- (b) Turn the panel mains isolate switch ON. When the green Power LED turns on (after approximately 30 seconds), connect the batteries.
- (c) Acknowledge all abnormal conditions by pressing the appropriate "ACK" (Alarm and Fault) pushbutton(s). Press the "ACK" pushbutton to review all abnormal conditions within each list. Once all abnormal conditions are cleared, press the "CLR" key.
- (d) Set the correct time and date. The system should then display "SYSTEM IS NORMAL" followed by the time and date.
- (e) Repair/restore all abnormal conditions. (refer Appendix A - Trouble shooting Procedures)

6. OUTPUT LEVEL ADJUSTMENTS

6.1 SPEAKER VOLUME ADJUSTMENT

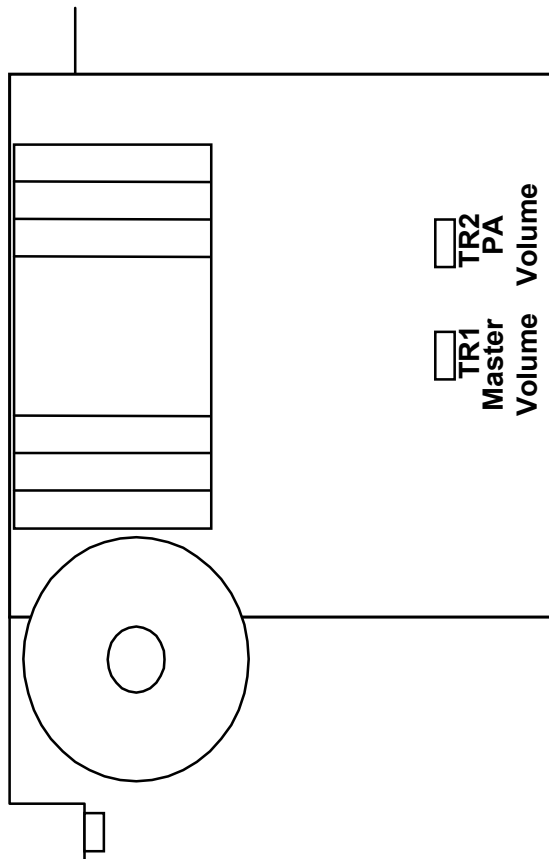

Speaker volume can be adjusted, using the variable resistors located on the Amplifier card.

To adjust the Speaker volume:-

(a) Locate **TR1 Master Volume** variable resistor on the **Amplifier board 8225 or 8250**. (See Figure 22)

(b) Use a screwdriver to adjust variable resistor to required output level.

- Turn the variable resistor clockwise to increase volume.
- Turn the variable resistor anti-clockwise to decrease volume.



Figure 22 Amplifier Card Adjustments for Speaker Adjustments

6.2 PA VOLUME ADJUSTMENT

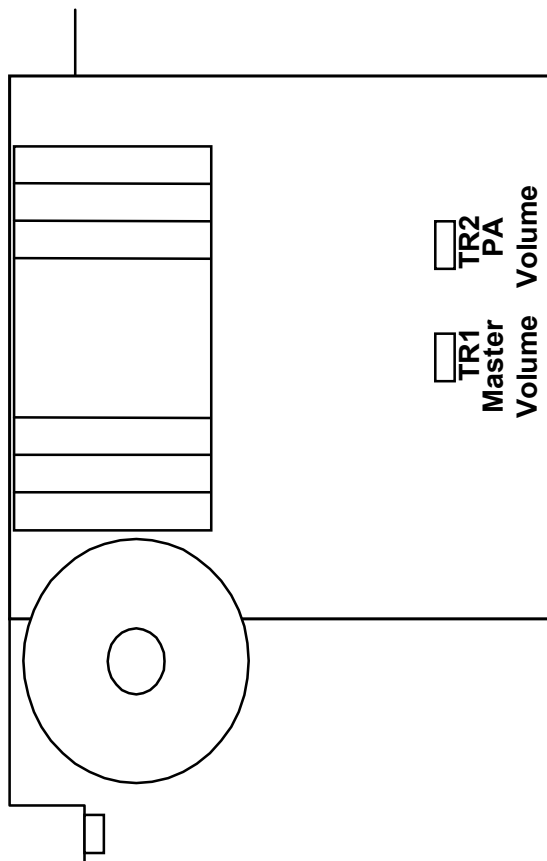

PA volume can be adjusted, using the variable resistor located on the Amplifier card.

To adjust the Speaker volume:-

- (a) Locate **TR2 PA Volume** variable resistor on the **Amplifier board 8225 or 8250**. (See Figure 23)
- (b) Use a screwdriver to adjust variable resistor to required output level.
 - Turn the variable resistor clockwise to increase volume.
 - Turn the variable resistor anti-clockwise to decrease volume.



Figure 23 Amplifier Card Adjustments for PA Adjustments

6.3 SPEECH MICROPHONE LEVEL ADJUSTMENT

Note: There is no adjustment for the MECP microphone or the SECP microphone levels.

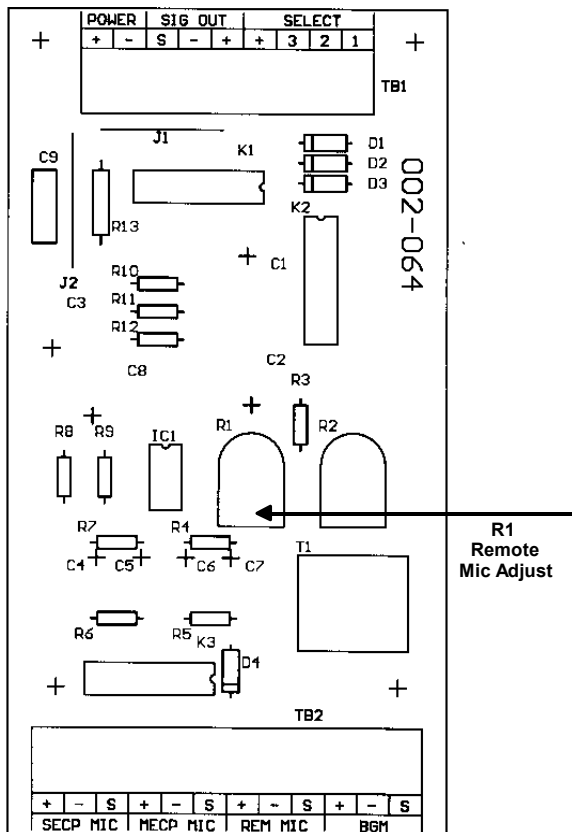

There is an adjustment facility available for a remote microphone if fitted.

To adjust the remote microphone:-

- (a) Locate R1 variable resistor on the pre-amplifier board 002 – 064. (See Figure 24)
- (b) Use a screwdriver to adjust variable resistor to required output level.
 - Turn the variable resistor clockwise to increase volume.
 - Turn the variable resistor anti-clockwise to decrease volume.



Figure 24 Speech Adjustment

6.4 BACKGROUND MUSIC ADJUSTMENT

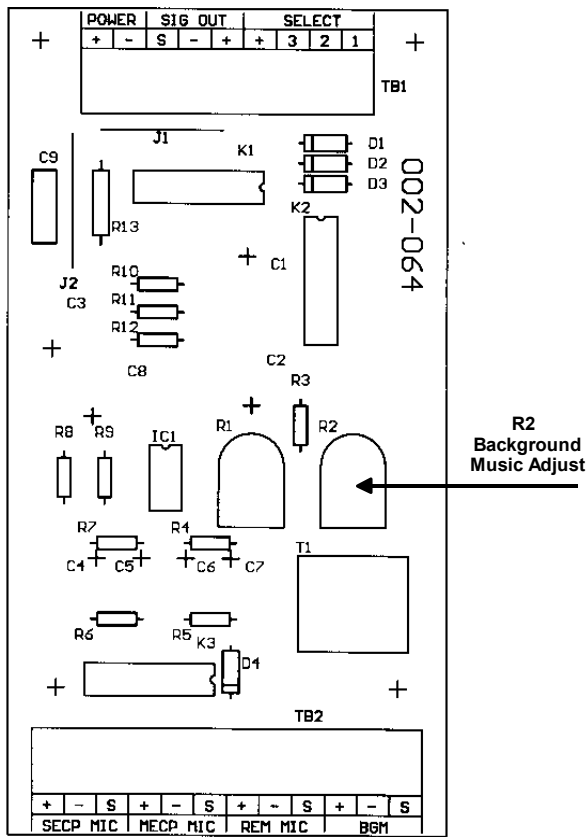

To adjust the background Music (BGM) output levels:-

- (a) Locate R2 variable resistor on the pre-amplifier board 002 – 064. (See Figure 25)
- (b) Use a screwdriver to adjust variable resistor to required output level.
 - Turn the variable resistor clockwise to increase volume.
 - Turn the variable resistor anti-clockwise to decrease volume.



Figure 25 BGM Adjustment

7 COMMISSIONING THE SYSTEM

7.1 COMMISSIONING CHECK LIST

JOB NAME:

JOB NUMBER:

PANEL SERIAL NUMBER:

Please place a tick in the space provided if check is correct. If not please give details.

Panel Check List	Y	N
Cabinet undamaged (no paint chips, door aligned).....	<input type="checkbox"/>	<input type="checkbox"/>
Power Point fitted and wired correctly.....	<input type="checkbox"/>	<input type="checkbox"/>
All cabinet earths wired correctly and securely fitted.....	<input type="checkbox"/>	<input type="checkbox"/>
Battery Capacity.....	_____	
All Print Circuit Boards securely fitted	<input type="checkbox"/>	<input type="checkbox"/>
Identification Label Completed	<input type="checkbox"/>	<input type="checkbox"/>
Power Up	Y	N
Charger output voltage at BATT +27.6VDC (@ 20 deg)	<input type="checkbox"/>	<input type="checkbox"/>
Quiescent panel current from battery (Mains Isolated).....	_____	
Lamp Test OK.....	<input type="checkbox"/>	<input type="checkbox"/>
Display LEDs aligned and all intensities similar.....	<input type="checkbox"/>	<input type="checkbox"/>
Function keys aligned and operate easily	<input type="checkbox"/>	<input type="checkbox"/>

Manual Mode Test – Each Zone	Y	N
Alert Tone OK	<input type="checkbox"/>	<input type="checkbox"/>
Evac Tone OK.....	<input type="checkbox"/>	<input type="checkbox"/>
PA Speech OK.....	<input type="checkbox"/>	<input type="checkbox"/>
Visual Output OK	<input type="checkbox"/>	<input type="checkbox"/>
Fault Modes Operating Correctly	<input type="checkbox"/>	<input type="checkbox"/>
- WIP Lines - O/C & S/C	<input type="checkbox"/>	<input type="checkbox"/>
- Speaker lines - O/C & S/C.....	<input type="checkbox"/>	<input type="checkbox"/>
- Strobe lines - O/C & S/C.....	<input type="checkbox"/>	<input type="checkbox"/>
- FIB lines - O/C	<input type="checkbox"/>	<input type="checkbox"/>
- BGA lines - O/C.....	<input type="checkbox"/>	<input type="checkbox"/>
 Auto Mode Test	 Y	 N
Time delays operate as programmed.....	<input type="checkbox"/>	<input type="checkbox"/>
Passed 24 hour burn-in period	<input type="checkbox"/>	<input type="checkbox"/>
 TEST COMPLETED, passed Q/A check.....	 <input type="checkbox"/>	 <input type="checkbox"/>
Name of Tester		
Signature.....		
Date of Test.....		

7.2 BATTERY/BATTERY CHARGER DETAILS

- (a) Battery type and capacity _____
- (b) Float charge voltage _____
- (c) Terminal volts _____
- (d) Discharge rate _____
- (e) Date battery installed _____
Replacement date _____
- (f) Maximum discharge current @ 1.5 hour rate _____
- (g) Full load current of system _____
- (h) Rated output current of battery charger(s) _____

7.3 SYSTEM TEST PROCEDURES

Note: These procedures should be followed when the system is first installed, during periodic tests, or as required by local code. Check local codes to determine how frequently your system should be tested. Always inform appropriate personnel that you will be testing the system (city Fire Brigade, customer, etc.).

7.4 LAMP TEST

The lamp test pushbutton on the control panel is used to determine local lamp failures within the system. Only lamps on the 4100 control panel will illuminate along with the five function and acknowledge LEDs. All segments on the LCD will also change. Perform the following procedures to determine lamp failure:

- (a) Press the "LAMP TEST" pushbutton.

All LEDs should illuminate (lamps should stay illuminated as long as the pushbutton is depressed). Holding the Lamp Test pushbutton in for more than three seconds will test the piezo.

- (b) Perform an individual lamp test on all remote annunciators, to include the 24 point I/Os, RCUs, SCUs and LED/switch modules.
- (c) Remove and replace defective lamp(s).

Note: The serial annunciator lamps/LEDs will not illuminate during the lamp test.

7.5 REMOUNTING RETAINER

- (a) Install the retainer assembly onto the back box assembly utilising the two bottom hook-tabs and secure it by using two plastic squeeze release tabs located on the upper centre of the retainer assembly.
- (b) Install two screws to secure the retainer assembly, one at the top centre of the retainer assembly and the other at the bottom centre of the retainer assembly.

Note: The two screws must be installed to ensure proper ESD (electro-static discharge) protection.

- (c) Close and lock the door assembly.

8. APPENDIX A – TROUBLE SHOOTING PROCEDURE

8.1 GENERAL TROUBLESHOOTING INFORMATION

Before troubleshooting the system, notify the customer and monitoring facility that you are repairing the system and may trip an alarm. Local codes may require notification of additional personnel, therefore check local codes for these requirements.

Tools required are a multimeter, side cutting pliers, IC removal/insertion tool (optional) and two sizes of screwdriver to accomplish these procedures. It is also recommended that Field Wiring Diagrams be used as required.

8.2 TROUBLESHOOTING CHART

The “Voltage Chart” shown on the following page contains voltage readings for various motherboard terminals and connectors and is to be used as required. Do not take voltage readings on the system printed circuit board IC’s.

When troubleshooting the 4100 system, check the obvious things first. These are the LEDs, toggle switches, dip switch settings, power, clipped jumpers, resistors, city jumpers and wiring to include contractor installed field wiring, all of which are located in the fire alarm panel. Perform a visual inspection of the panel.

The following indications should be observed on the fire alarm panel.

- (i) Normal LED indications.
 - (a) Green “Power” LED is illuminated.
 - (b) All other LEDs are OFF.

Note: If the green power LED is not illuminated, check the AC input voltage.

- (ii) Toggle switches are in the down (normal) position.
- (iii) Fuses are good and are the correct values.
- (iv) Ensure dipswitches are properly set.
- (v) Field wiring is correct (see Field Wiring Diagrams).
- (vi) Correct jumpers and resistors are clipped.
- (vii) Ribbon cables are properly installed.

If the alphanumeric display shows an abnormal indication on a module, troubleshoot that circuit/printed circuit board first. Check the return field wiring to that printed

circuit board to ensure proper voltage and signals are present. If these signals and voltages are incorrect, the printed circuit board is probably defective.

If the visual inspection of the panel was normal, and the voltages are correct, the next step in sectionalisation is to test the return field wires from the peripheral devices. This is the next section to troubleshoot because proper voltage terminals are accessible which allows these checks to be made quickly. Check for incorrect voltage or signal with voltmeter. If an incorrect reading is observed, you know the defective printed circuit board is the one you are testing.

If the voltage and signals are correct on the return field wiring, the next step is to localise the trouble by swapping printed circuit boards of the same type. Perform the following procedure to swap printed circuit boards:

1. Disconnect battery power.
2. Turn system power OFF (AC).
3. Remove the suspected printed circuit board from the motherboard.
4. Remove a printed circuit board of the same type from the system (when available) or from branch stock.
5. Set the "good" printed circuit board address to match the white "address label" on the motherboard (where the "bad" printed circuit card was located). If a printed circuit board is swapped from within the system, set the "bad" printed circuit board address to match the white "address label" on the motherboard (where the "good" printed circuit board was located).
6. Install both printed circuit boards ("good" and "bad").
7. Apply AC power to the system.
8. Apply DC power to the system.
9. "ACK" all abnormal conditions.

If the visual indications change, the problem is in the "bad" printed circuit board. If the symptoms do not change, check inputs and outputs from the now "good" printed circuit board.

Voltages and signals on the terminals should match the Voltage Chart shown below. Note the voltages given in the chart are with reference to the negative (-) of the 24V power Supply. When field wiring is removed, remove and mark one wire at a time. Ensure that the wiring is properly replaced to prevent additional fault indications. Use the Voltage Chart as required.

	Positive Terminal	Negative Terminal	
	28 VDC	3 VDC	Normal Circuit

MONITOR CIRCUIT	28 VDC	6-18 VDC	Current Limited Alarm
	28 VDC	28 VDC	Short Circuit Alarm
	28 VDC	0 VDC	Open Circuit
SIGNAL CIRCUIT	7 VDC	28 VDC	Normal Circuit
	28 VDC	0 VDC	Alarm Condition
	0 VDC	28 VDC	Open Circuit
	16 VDC	28 VDC	Installed Reverse Polarity
SUPERVISED ANNUNCIATOR	28 VDC	25 VDC	Normal Circuit
	28 VDC	0 VDC Pulsing	Alarm Condition
	0 VDC	0 VDC	Lost Annunciation Common
	28 VDC	0 VDC	Open Circuit

Figure 26 Voltage Chart

10. Verify the ground status of the system by connecting the negative (black) lead of a voltmeter to the Earth Ground and connect the positive (red) lead of the voltmeter to the positive (+) terminal of the 24V DC supply and check for the following readings:

Voltage Reading	Circuit Status
12-14V DC	Normal
6-12V DC	Partial Negative Ground
15-21V DC	Partial Positive Ground

8.3 GENERAL SYSTEM FAULTS

FAULT / STATUS	POSSIBLE CAUSE	SOLUTION
Mains ON indicator is OFF	<ul style="list-style-type: none"> • Mains at Distribution board is OFF. • Mains Switch is OFF. • Mains Fuse Blown. 	<ul style="list-style-type: none"> • Turn Power ON. • Turn Mains Switch ON. • Replace Fuse 8 Amp.
System on Batteries	<ul style="list-style-type: none"> • Mains at Distribution board is OFF. • Mains Power Failure. • Mains Switch off. • Mains Fuse Blown. 	<ul style="list-style-type: none"> • Turn Power ON, check for mains on indicator when power is returned. • Turn Mains Switch ON. • Replace Fuse 8 Amp.
Charger Fault	<ul style="list-style-type: none"> • Mains Fail. • High volts: Charger output volts above 28.5 volts. • Low volts: Charger output volts below 24.5 volts. • Batteries fault: Voltage below 24.5 volts • Batteries Disconnected 	<ul style="list-style-type: none"> • Reference mains on indicator, and System on batteries. Fault status. • Replace Power Supply. • Replace Power Supply. • Replace Batteries • Connected Batteries

FAULT / STATUS	POSSIBLE CAUSE	SOLUTION
Communication Fault	<ul style="list-style-type: none"> • Section of the RS 485 loop faulty or disconnected from module. 	<ul style="list-style-type: none"> • Check section and termination, or field wiring. • Check internal comms connections. • Ensure all modules are plugged in. Ensure modules are installed in correct order.
System Fault	<ul style="list-style-type: none"> • Module or CPU within entire system faulty 	<ul style="list-style-type: none"> • Identify MECP or SECP display module or CPU fault. Ref module fault or CPU fault instructions.
Module Fault	<ul style="list-style-type: none"> • Faulty Module 	<ul style="list-style-type: none"> • Replace Module
EWIS Zone Fault in Amplifier / Speaker.	<ul style="list-style-type: none"> • Speaker cabling fault. • Short or Open circuit cable. • No EOL resistor. • No DC isolation capacitor fitted (incorrect speaker type). <p>Amplifier Faulty</p> <ul style="list-style-type: none"> • Faulty amplifier • Blown fuse. 	<ul style="list-style-type: none"> • Check as instructed in installation manual. • Fit 10k EOL resistor. • Fitted capacitors or change speaker. • Replace amplifier. • Replace fuse. 5 amp 3AG.

FAULT / STATUS	POSSIBLE CAUSE	SOLUTION
EWIS Zone fault Visual	<ul style="list-style-type: none">• Visual cable fault.• Fuse blown on signal card.	<ul style="list-style-type: none">• Check cabling and connections.• Replace fuse. 2 amp 3AG.
EWIS Zone fault Alarm system.	<ul style="list-style-type: none">• Alarm system cabling fault.• Open circuit cable to alarm.• No EOL resistor at alarm system.	<ul style="list-style-type: none">• Check cabling and connections.• Install 3k3 resistor at alarm system end of cable.
EIS Zone fault	<ul style="list-style-type: none">• WIP cabling fault.• Fuse blown on signal card.	<ul style="list-style-type: none">• Check cabling and connections.• Replace 2 amp fuse.

9. APPENDIX B - EWIS 4100 FAULT MESSAGES

9.1 CARD TROUBLES

If the LCD displays ... **Wrong Card Abnormal**

- 1st Line Shows Card Expected at this Address.
Reprogram System or Insert Proper Daughter Card.

If the LCD displays ... **Extra Card Abnormal**

- A Daughter Card is/was installed but not Programmed.
Reprogram System or Remove Extra Daughter Card.
- * Warm Start is Necessary to Clear this Trouble Condition. Press the CPU Reset Switch located on the Master Controller Board.

If the LCD displays ... **Card Missing/Failed**

- Identify Card from LCD.
- Is Communication Trouble LED illuminated on Card ?
- Check Dipswitch Setting with Programmer's Report.
- Check for 8VDC & 24VDC at Motherboard Harness P3.
- Check for Serial Comm at Motherboard Harness P2.
- * If ALL Daughter Cards Report Missing/Failed Check Serial Comm fuse on Master Controller Board (F6).

☞ If this Trouble only Occurs upon Alarm, Alarm Silence or System Reset it may be Caused by Unsuppressed Relays, Door Magnets, High Current Loads, etc.

9.2 BATTERY TROUBLES

If the LCD displays ... ***Master Battery Backup Status is Trouble***

- Check connector P9 on Master Power Supply.
- Check that Batteries Terminals are Connected.
- Check Fuse(s) in the Battery Harness.
- Check for Charger Output at Battery Harness Terminals with the Batteries Disconnected.
- Measure Battery voltage with Terminals from Harness Disconnected. (>18 VDC)
- Test Batteries under load for 1 minutes. (>23 VDC)

9.3 EARTH GROUNDS

If the LCD displays ... ***Master Earth Status is Trouble***

- Is Ground on Positive/Negative side of Power Supply ?
- If a Positive Ground ... Remove half of the Motherboards.
Isolated to a Row ... Remove half of the Daughter cards.
- If a Negative Ground ... Check Power, and Shields.
- Ground could be Internal to the Control Panels.

9.4 ANNUNCIATOR TROUBLES

If the LCD displays ...

***Card X, Led (Switch) Display Slot X
Card Defined But Not Inserted***

- Annunciator Display Card Programmed in Software but not connected via the Ribbon Cable.

If the LCD displays ...

***Card X, Led (Switch) Display Slot X
Card Not Defined But Inserted***

- Annunciator Display Card not Programmed in Software but connected via the Ribbon Cable.
- * Check ribbon cable or Verify Annunciator Programming.

9.5 4100 LCD DISPLAY FAULT MESSAGES TABLE

IF THE LCD DISPLAYS	POSSIBLE CAUSE	SOLUTION
<i>OPEN CIRCUIT FAULT SPEAKER LINE</i>	<ul style="list-style-type: none"> • Speaker cabling fault. • Open circuit cable. • No EOL resistor. • No DC isolation capacitor fitted (incorrect speaker type). 	<ul style="list-style-type: none"> • Check as instructed in installation manual. • Fit 10k EOL resistor. • Fitted capacitors or change speaker.
<i>SHORT CIRCUIT FAULT SPEAKER LINE WITH AMPLIFIER OFF</i>	<ul style="list-style-type: none"> • Speaker cabling fault. • Short circuit cable. • No EOL resistor. • No DC isolation capacitor fitted, (incorrect speaker type). 	<ul style="list-style-type: none"> • Check as instructed in installation manual. • Fit 10k EOL resistor. • Fitted capacitors or change speaker.
<i>AMPLIFIER FAILURE</i>	<ul style="list-style-type: none"> • Faulty amplifier • Blown fuse. • Faulty Ribbon Cable. 	<ul style="list-style-type: none"> • Replace amplifier. • Replace fuse. 5 amp 3AG. • Replace Ribbon Cable.
<i>OPEN CIRCUIT WIP LINE</i>	<ul style="list-style-type: none"> • Speaker cabling fault. • Open circuit cable. • No EOL resistor. 	<ul style="list-style-type: none"> • Check as instructed in installation manual. • Fit 10k EOL resistor.
<i>SHORT CIRCUIT WIP LINE</i>	<ul style="list-style-type: none"> • Speaker cabling fault. • Open circuit cable. • No EOL resistor. 	<ul style="list-style-type: none"> • Check as instructed in installation manual. • Fit 10k EOL resistor.
<i>OPEN CIRCUIT BGA INPUTS</i>	<ul style="list-style-type: none"> • Cabling fault. • Open circuit cable. • No EOL resistor. 	<ul style="list-style-type: none"> • Check as instructed in installation manual. • Fit 3k3 EOL resistor.

IF THE LCD DISPLAYS	POSSIBLE CAUSE	SOLUTION
<p>CARD XX POWER SUPPLY / CHARGER</p> <p>AC VOLTAGE ABNORMAL</p>	<ul style="list-style-type: none"> • Mains at Distribution board is OFF. • Mains Switch is OFF. • Mains Fuse Blown. 	<ul style="list-style-type: none"> • Turn Power ON. • Turn Mains Switch ON. • Replace Fuse 8 Amp.
<p>CARD XX SWITCHED TO BATTERIES</p>	<ul style="list-style-type: none"> • Mains at Distribution board is OFF. • Mains Power Failure. • Mains Switch off. • Mains Fuse Blown. 	<ul style="list-style-type: none"> • Turn Power ON, check for mains on indicator when power is returned. • Turn Mains Switch ON. • Replace Fuse 8 Amp.
<p>BATTERY LOW</p> <p>BATTERY DISCHARGED</p> <p>BATTERY CHARGER CAPACITY XX</p>	<ul style="list-style-type: none"> • Mains Fail. • High volts: Charger output volts above 28.5 volts. • Low volts: Charger output volts below 24.5 volts. • Batteries fault: Voltage below 24.5 volts • Batteries Disconnected 	<ul style="list-style-type: none"> • Reference mains on indicator, and System on batteries. Fault status. • Replace Power Supply. • Replace Power Supply. • Replace Batteries • Connected Batteries

IF THE LCD DISPLAYS	POSSIBLE CAUSE	SOLUTION
<i>NETWORK HAS FAILED</i> <i>NETWORK GROUND FAILED</i> <i>NETWORK IS OPERATING IN DEGRADED STATE *7</i>	<ul style="list-style-type: none">• Section of the RS 485 loop faulty or disconnected from module.	<ul style="list-style-type: none">• Check section and termination, or field wiring.• Check internal comms connections.• Ensure all modules are plugged in. Ensure modules are installed in correct order.

This page intentionally left blank

10. APPENDIX C LIST OF INSTALLED EQUIPMENT

Evacuation Zone	Fire Zone	Loud Speaker			Amplifier		Visible Signals		WIPs
		Qty	Power Tap	Total Load	Qty	Total Rating	A	E	Qty
1									
2									
3									
4									
5									
6									
7									
8									
9									
10									
11									
12									
13									
14									
15									
16									
17									
18									
19									
20									
21									
22									
23									
24									
25									
26									
27									
28									
29									
30									
31									
32									
33									
34									
35									
36									
37									
38									
39									
40									

Evacuation Zone	Fire Zone	Loud Speaker			Amplifier		Visible Signals		WIPs
		Qty	Power Tap	Total Load	Qty	Total Rating	A	E	Qty
41									
42									
43									
44									
45									
46									
47									
48									
49									
50									
51									
52									
53									
54									
55									
56									
57									
58									
59									
60									