

# FREEDOM 6000 TRANSMITTER

FEATURING IR COMBUSTIBLE GAS SENSOR

## Simple. Safe. Smart. Scott.

The oil and gas industry, along with general industrial facilities, spend millions of dollars each year on the gas detection equipment required to detect atmospheric hazards in the workplace. With the introduction of the Scott Freedom 6000 Universal Transmitter for the detection of high or low oxygen concentrations, toxic gases, and combustible gases, Scott Health & Safety is making it easier than ever before to install, integrate and maintain a gas detection system within a facility. Whether working to detect H<sub>2</sub>S in a refinery or screening for methane in an industrial application, the Freedom 6000 Transmitter can be a perfect fit for your application.

The Freedom 6000 Transmitter provides a solid foundation for our growing Freedom 6000 product family. At the core of the Freedom 6000 Transmitter is our distinctive plug and play sensor technology. When coupled with our modular infrared gas sensor, the Freedom 6000 Transmitter provides a new level of simplicity for protection including detecting the presence of hydrocarbons.

## Applications:

- Oil and Gas Production Platforms
- Refineries
- Gas Collection and Distribution Facilities
- LNG/LPG Processing and Storage Facilities
- Chemical Plants
- Solvent Vapors
- Wastewater Treatment Facilities
- General Industry



## PRODUCT HIGHLIGHTS

- Modular Design for Easy In-Field Service
- Plug and Play Sensor Technology
- View Trends, Events, and Conditions at a Glance
- Monitors and Alerts Low Sensor Life
- Scott Smart Technology Recognizes Sensor Changeout



**SCOTT**  
HEALTH & SAFETY

# FREEDOM 6000 TRANSMITTER

FEATURING IR COMBUSTIBLE GAS SENSOR



With the Freedom 6000 IR, Scott has developed a simple and reliable technology solution, which improves the safety of the workplace and savings to our customers.

## Simple

- Modular system enabling component replacements and upgrades
- Large backlit display facilitates quick review of trend data and analysis
- Corrosion resistant housing protects sensors from the environment and contamination

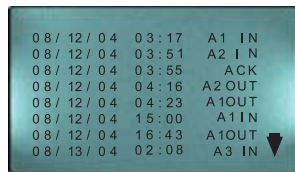
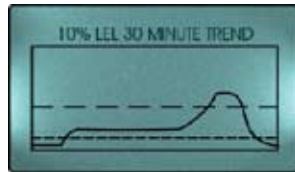
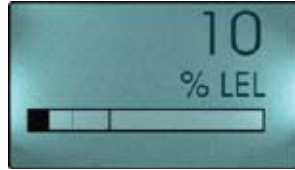

## Safe

- Meets design and performance requirements for UL, ATEX, and CSA certification
- Meets NEMA 4x/IP66 standard confirming the instruments performance in harsh environments

## Smart

- Reduces inventory costs with one transmitter for multiple applications
- Reduces cost of ownership with a modular component system allowing simple in-field repair, product modification, and technology upgrades
- Reduces training costs associated with operating and maintaining multiple products

## Scott

- Two year warranty on sensor and electronics
- Global service centers which include 28 factory authorized service centers in North America for warranty and non-warranty work
- Technical Support team members readily available to assist you in a variety of applications and uses

## Technical Specifications

- Sensor:** Miniaturized Infrared Sensor Measurement  
Range: 0-100% LEL.
- Outputs:** 3-Wire 4-20mA into 750 ohms Max @ 24VDC; 750 ohms Max Loop Load (**Optional**) isolated 4-20mA with 1500v isolation between signal and transmitter power supply. (**Optional**) RS-485 is 2-Wire ModBus RTU.
- Relays:** RS-485 ModBus (**Optional**) Relays are Form C 5AMP @ 30VDC & 240VAC Resistive.
- Display:** 64 x 128 pixel LCD displays 30-minute trend, bar graph & large engineering units. Back light active in 3-Wire 4-20mA mode.
- Accuracy:** ± 2% of full scale.
- Power:** 10-30VDC at < 3 watts in 3-Wire 4-20mA with Relays.
- Housing:** NEMA-7 Aluminum Explosion-proof Instrument Enclosure suitable for Cl. 1, Div. 1 & 2, Gr. B,C,D. Meets NEMA-4 requirement with standard "o-ring"
- Weight:** 4.25 lbs
- Environmental:** Transmitter: -40°F to 140°F (-40°C to 60°C). < .1% drift per °C over ambient temp. range.  
Sensor: -40°F to 200°F (-40°C to 93°C), 0 to 99% RH, Non-condensing.

## Approvals:

- Housing:** II 2GD EEx d IIC
- Compliance with:** EN 50014: 1997 + A1 + A2 and EN 50018: 2000 and EN 50281-1-1: 1998
- Explosion proof for Class I, Division 1, Groups A, B, C and D; and Dust-Ignition proof for Class II/III, Division 1, Groups E, F and G; hazardous (classified) locations, indoor/outdoor (NEMA Type 4X). Class I, Division 1, Groups A, B, C and D; Class II, Groups E, F and G; Class III: Universal Instrument Housings, Type 4X, -40°C to +100°C and -40°C to +85°C. All openings for conduit and sensor connection must be in NPT threads. For Class I Group A installation, conduit is required.
- 

- Complete Instrument:** II 2 G EEx d IIB + H2 T5 -20°C ≤ Ta ≤ +60°C
- Compliance with:** EN 50014: 1997 + A1: 1999 + A2: 1999 and EN 50018: 2000 + A1: 2002, EN 60079-0: 2006, EN 60079-1: 2004

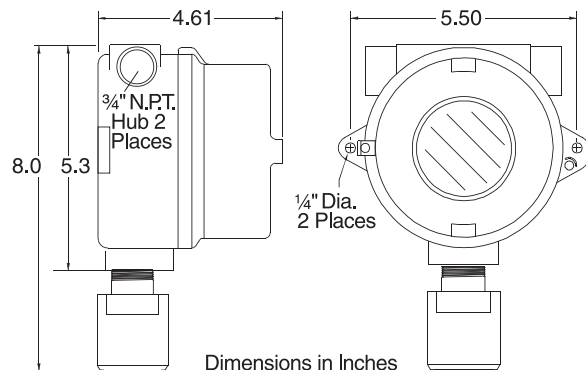

Monroe Corporate Center • P.O. Box 569 • Monroe, NC 28111  
Telephone: 800.247.7257 • Facsimile: 704.291.8330  
www.scotthealthsafety.com • sh-sale@tycoint.com

**SCOTT**  
HEALTH & SAFETY